

# Technical Service Guide

June 2009

## Monogram Professional Range and Rangetops

ZDP486ND  
ZDP486NR  
ZDP484NG  
ZDP364ND  
ZDP364NR  
ZDP366N  
ZDP304N

ZGU366N  
ZGU364ND  
ZGU364NR  
ZGU486ND  
ZGU484NG  
ZGU486NR

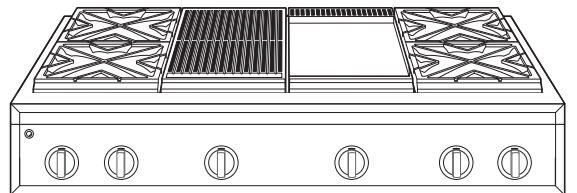
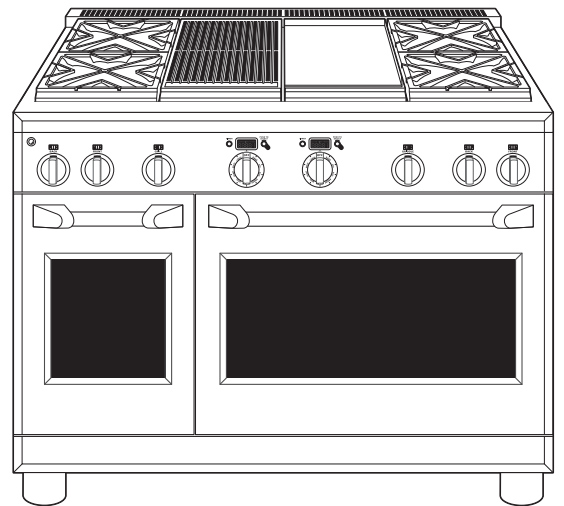

31-9181



GE Appliances  
General Electric Company  
Louisville, Kentucky 40225



### **IMPORTANT SAFETY NOTICE**

The information in this service guide is intended for use by individuals possessing adequate backgrounds of electrical, electronic, and mechanical experience. Any attempt to repair a major appliance may result in personal injury and property damage. The manufacturer or seller cannot be responsible for the interpretation of this information, nor can it assume any liability in connection with its use.

### **WARNING**

If the information in this manual is not followed exactly, fire or explosion may result causing property damage, personal injury or death. If you smell gas:

- Do not try to light any appliance.
- Do not touch any electrical switch; do not use any phone in the building.
- Immediately call the gas supplier from a neighbor's phone. Follow the gas supplier's instructions.
- If you cannot reach the gas supplier, call the fire department.

### **WARNING**

To avoid personal injury, disconnect power before servicing this product. If electrical power is required for diagnosis or test purposes, disconnect the power immediately after performing the necessary checks.

### **RECONNECT ALL GROUNDING DEVICES**

If grounding wires, screws, straps, clips, nuts, or washers used to complete a path to ground are removed for service, they must be returned to their original position and properly fastened.

***GE Consumer & Industrial***  
*Technical Service Guide*  
Copyright © 2009

All rights reserved. This service guide may not be reproduced in whole or in part in any form without written permission from the General Electric Company.

## Table of Contents

Back Panel.....	47
Bake Element.....	61
Broil Elements.....	56
Component Locator Views.....	27
Control Board Connector Locator.....	68
Control Features - Range.....	11
Control Features - Rangetop.....	8
Control Panel .....	30
Convection Bake Element.....	57
Convection Fan Assembly.....	58
Cooling Fan.....	48
Diagnostics and Service Information .....	71
Door Assembly.....	51
Electronic Oven Control .....	67
Factory Test Mode .....	71
Gas Conversion Range and Rangetop.....	22
Glow-bar Igniter .....	39
Griddle Assembly .....	35
Griddle Burner Igniter .....	37
Griddle Control .....	37
Griddle Safety Valve .....	37
Grill and Griddle Ignition Systems .....	38
Grill Assembly .....	31
Grill Burner Igniter .....	33
Grill Control .....	34
Grill Safety Valve .....	33
Indicator Light Assembly.....	46
Installation .....	19
Introduction.....	5
LED Lights and Power Supply .....	45
Lock Assembly.....	49

Meat Probe Receptacle and Harness.....	63
Nomenclature - Range.....	6
Nomenclature - Rangetop.....	7
Optional Accessories.....	84
Oven Component Circuits.....	81
Oven Components .....	51
Oven Control Logic Board .....	60
Oven Light Assemblies .....	65
Oven Operational Notes.....	25
Oven Racks.....	54
Oven Relay Board .....	60
Oven Sensor, Sail, and Door Switch Test.....	76
Oven TCO.....	49
Oven Temperature Sensor.....	56
Range Components.....	47
Sail Switch.....	49
Schematics and Wiring Diagrams.....	77
Side Access Panel.....	47
Spark Module .....	43
Surface Burner .....	41
Surface Burner Base .....	39
Surface Burner Igniter.....	40
Surface Burner Pan .....	40
Surface Burner Valve and Switch .....	42
Surface Component Circuits .....	79
Surface Components.....	30
Task Light Switch .....	46
Transformer .....	44
Warranty-Range.....	86
Warranty-Rangetop.....	85

# Introduction

\*Monogram introduces the new GE Monogram Professional Range and Rangetops. Their superior style and performance parallel commercial units. Available in 48-, 36-, and 30-inch Ranges and 48- and 36-inch Rangetop models -- these units feature electronic dial controls that combine the precision of modern digital technology with the simplicity of traditional mechanical controls.

- Authentic Professional appearance using premium-grade, 304 stainless steel with smoothly finished edges, large electronic control knobs, and heavy duty handles.
- Sealed, dual-flame stacked burners deliver a full spectrum of heat settings, from an ultra-low 140°F simmer to an intense 18,000 BTUs.
- Electronic ignition with automatic reignition ensures a continuous flame which reignites automatically if accidentally extinguished.
- Reversible burner grates are flat on one side and uniquely contoured on the other to accommodate round-bottom woks.
- Stainless steel and aluminum-clad griddle offers 18,000 BTUs of cooking power, allowing fast and consistent heating across the entire cooking surface.
- Grill with infrared ceramic burner can be adjusted from 14,000 BTUs down to approximately 10,000 BTUs.
- Monogram Professional oven system combines European, reverse-air convection technology and six heating elements in each oven to provide superb baking results.
- Main ("Caterer's") oven is uniquely sized to accommodate three full-sized sheet trays.
- Companion ("Everyday") oven is just the right size for 9" x 13" casserole dishes.
- Halogen light columns provide a clear view, regardless of rack position.
- Heavy-duty, full-extension racks glide smoothly in and out on stainless steel ball bearings for easy access, and are designed to remain in the oven during the self-clean cycle.
- LED task lights below the bullnose provide a functional and theatrical touch.
- Optional Fixed- (12 inch ) or adjustable-height (30 to 36-inch) backsplashes with shelf are available.
- Optional black knob kit available.

\*Features may vary by model.



# Nomenclature - Range

## Model Number

Z D P 4 8 6 N D P S S

**Monogram Product**  
Monogram Pro Range

**Product Color**  
SS = Stainless Steel

**Width**  
48 = 48-in. Range  
36 = 36-in. Range  
30 = 30-in. Range

**Model Year Designator**

**Additional Cooking Surface**  
D = Griddle  
R = Grill  
G = Griddle and Grill  
None = All Burner Model

**Number of Surface Burners**  
4 = 4 Burners  
6 = 6 Burners

**Fuel Type**  
N = Natural Gas  
L = Liquid Propane



## Serial Number

The first two numbers of the serial number identify the month and year of manufacture.

Example: **AS123456S** = January, 2009

<b>A</b> - JAN	2009 - <b>S</b>
<b>D</b> - FEB	2008 - <b>R</b>
<b>F</b> - MAR	2007 - <b>M</b>
<b>G</b> - APR	2006 - <b>L</b>
<b>H</b> - MAY	2005 - <b>H</b>
<b>L</b> - JUN	2004 - <b>G</b>
<b>M</b> - JUL	2003 - <b>F</b>
<b>R</b> - AUG	2002 - <b>D</b>
<b>S</b> - SEP	2001 - <b>A</b>
<b>T</b> - OCT	2000 - <b>Z</b>
<b>V</b> - NOV	1999 - <b>V</b>
<b>Z</b> - DEC	1998 - <b>T</b>

The letter designating the year repeats every 12 years.

Example:  
T - 1974  
T - 1986  
T - 1998

The mini-manual is located at the bottom, behind the access panel.

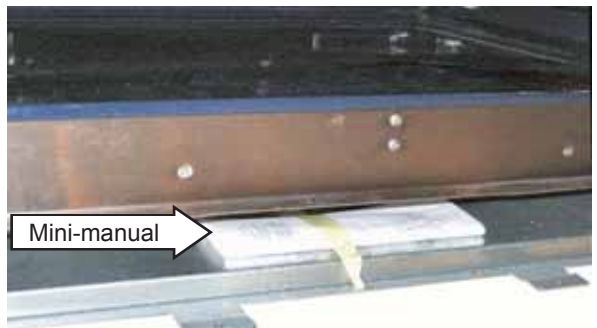

The nomenclature tag is located under the front control panel on the left side. The model and serial number are also on a tag located on the bezel behind the left front knob.

# Nomenclature - Rangetop

**Model Number**

Z G U 4 8 6 N D P S S

**Monogram Product**

Monogram Gas Rangetop

**Width**

48 = 48-in. Range  
36 = 36-in. Range

**Number of Surface Burners**

4 = 4 Burners  
6 = 6 Burners

**Product Color**

SS = Stainless Steel

**Model Year Designator**

**Additional Cooking Surface**

D = Griddle  
R = Grill  
G = Griddle and Grill

**Fuel Type**

N = Natural Gas  
L = Liquid Propane

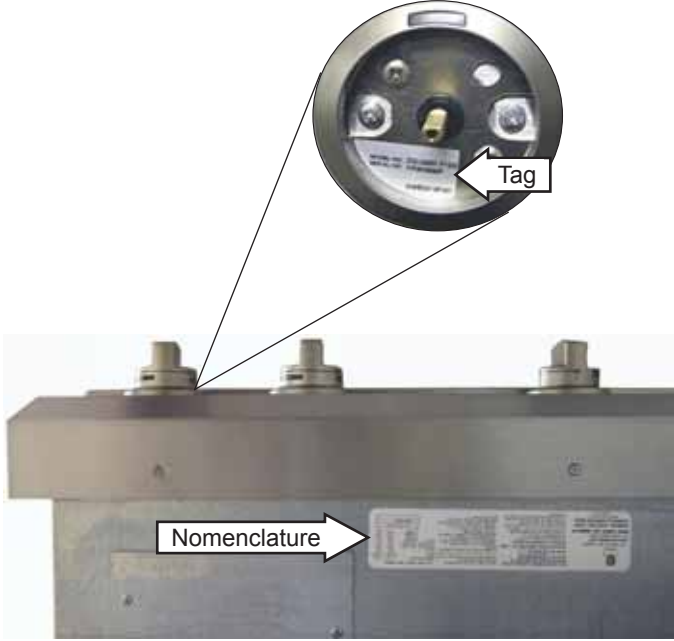

The nomenclature tag is located under the front control panel on the left side. The model and serial number are also on a tag located on the bezel behind the left front knob.

**Serial Number**

The first two numbers of the serial number identify the month and year of manufacture.

Example: **AS123456S** = January, 2009

<b>A</b> - JAN	2009 - <b>S</b>
<b>D</b> - FEB	2008 - <b>R</b>
<b>F</b> - MAR	2007 - <b>M</b>
<b>G</b> - APR	2006 - <b>L</b>
<b>H</b> - MAY	2005 - <b>H</b>
<b>L</b> - JUN	2004 - <b>G</b>
<b>M</b> - JUL	2003 - <b>F</b>
<b>R</b> - AUG	2002 - <b>D</b>
<b>S</b> - SEP	2001 - <b>A</b>
<b>T</b> - OCT	2000 - <b>Z</b>
<b>V</b> - NOV	1999 - <b>V</b>
<b>Z</b> - DEC	1998 - <b>T</b>

The letter designating the year repeats every 12 years.

Example:

T - 1974  
T - 1986  
T - 1998

The mini-manual is located on the bottom, next to the gas inlet pipe.

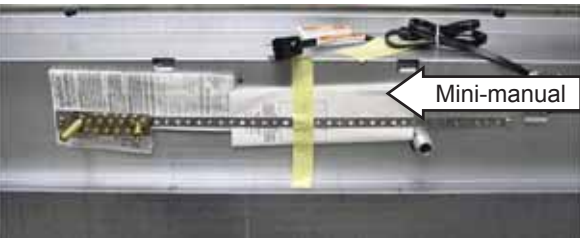

# Control Features - Rangetop

## Design information

(Not all features are on all models. Appearance may vary.)

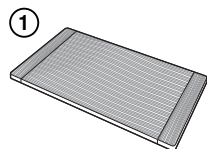

Bamboo Cutting Board



Grill and Griddle Covers

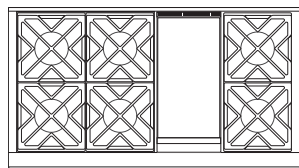

ZGU486NR, ZGU486LR-6 burners and grill  
ZGU486ND, ZGU486LD-6 burners and griddle

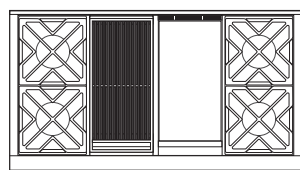

ZGU484NG, ZGU484LG  
4 burners, grill and griddle

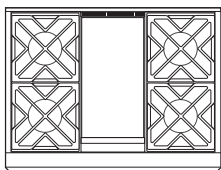

ZGU364NR, ZGU364LR-4 burners and grill  
ZGU364ND, ZGU364LD-4 burners and griddle

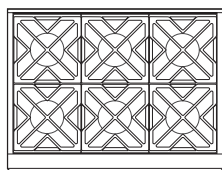

ZGU366N, ZGU366L  
6 gas burners

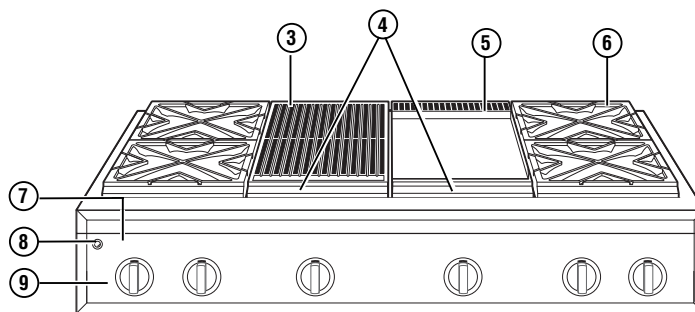

Number	Feature
1	Bamboo Cutting Board
2	Grill and Griddle Covers
3	IR (Infrared) Grill
4	Grill and Griddle Grease Troughs
5	Griddle
6	Rangetop Burner Grates
7	Burner Location Indicator
8	LED Bullnose Task Lighting Control
9	Burner Control Knob with Lighted Bezel

## Cooktop Controls

### Electronic Ignition and Automatic Reignition

The range is equipped with electronic ignition which eliminates the need for a standing pilot light.

The burners on this range will automatically relight if the flame goes out.

All surface burner igniters will spark and make clicking sounds when any burner is turned on or if automatic reignition occurs. Do not touch any of the burners when igniters are clicking.

Occasionally the burners may spark if excess wind or a draft blows the flame away from the burner's flame sensor.

The griddle and IR (infrared) grill are equipped with Glo-Bar igniters. The Glo-Bar remains energized whenever the griddle or IR grill is in use to ensure the burner always stays lit.

**In case of a power outage**, you can light the surface burners on your cooktop with a match. Hold a lighted match to the burner, then turn the knob to the **LOW** position. **Use extreme caution when lighting burners this way.**

Do not attempt to light the grill or griddle during a power outage. The gas to these burners will automatically shut off during a power outage.

### To Light a Surface Burner

Push the control knob in and turn it **counterclockwise** to the **LITE** position.

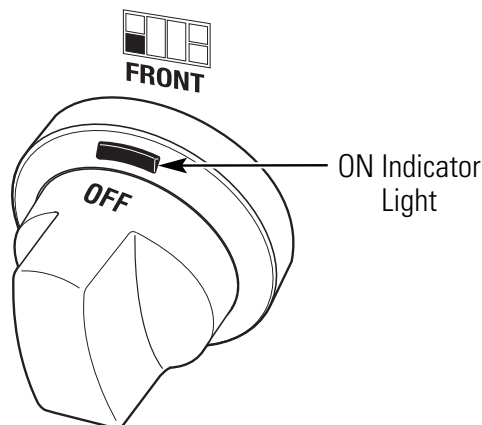

**After the burner ignites**, turn the knob to adjust the flame size.

**To turn a burner off**, turn the knob clockwise, as far as it will go, to the **OFF** position.

- Do not operate a burner for an extended period of time without cookware on the grate. The finish on the grate may chip without cookware to absorb the heat.
- The indicator light on each bezel verifies the burner is on. However, it should not be a substitute for visually checking the flame at the burner.

### Dual-flame Stacked Burners

All surface burners on your range have two sets of flames stacked one on top of the other; the dual-flame burners have a lower (simmer) flame and a upper (main) flame.

When a burner is turned on, the lower flame will always light and stay on.

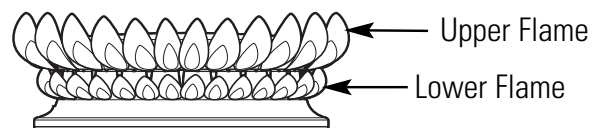
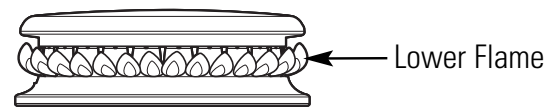

### Simmering:

The stacked burner design provides a wide range of heat settings with which to simmer. Depending on the type and quantity of food, and pan size, the flame can be adjusted to suit your specific need. The lowest setting uses only the lower flame and can maintain delicate foods at a safe 140°F.

### Cooking:

Settings from **LO** to **X-HI** will use both upper and lower flames. Use **LO** to **HI** for all purpose cooking. Use **HI** or **X-HI** (highest setting) with larger diameter cookware.

**X-HI** and **HI** are very high heat settings and are intended to sear foods quickly and boil large quantities of water.

(Continued next page)

## Using the IR Grill

**Remove the cover** before lighting the burner. The cover must be removed when using the IR grill.

Set the control knob to **PREHEAT**. The longer the grill is preheated, the darker the grill marks will be on the food.

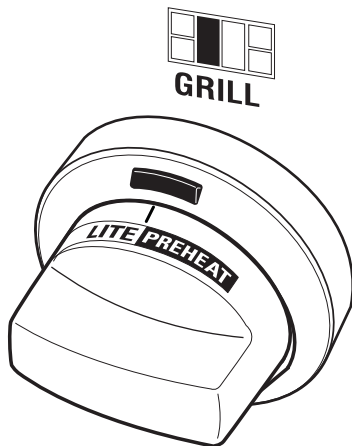

It may take up to 15 minutes to fully preheat the grill.

After preheat, the control knob may be set to any position between **HI** and **LO**.

**Do not leave the grill unattended at any time.**

**Note:** The grill will take approximately 45 seconds to ignite. Unlike the surface burners, which use electric igniters, the grill uses a Glo-Bar for ignition. It takes approximately 45 seconds for the Glo-Bar to reach temperature. Gas is only supplied to the grill once the Glo-Bar reaches temperature.

## Using the Griddle

The griddle is thermostatically controlled and can be set to maintain any temperature from 200°F to 450°F.

**Note:** Unlike the surface burners, which use electric igniters, the griddle uses a Glo-Bar for ignition. It takes approximately 45 seconds for the Glo-Bar to reach temperature. Gas is only supplied to the griddle once the Glo-Bar reaches temperature.

To heat the griddle, push in the control knob and turn to the desired Temperature setting. The light on the bezel will glow to indicate the thermostat control is working.

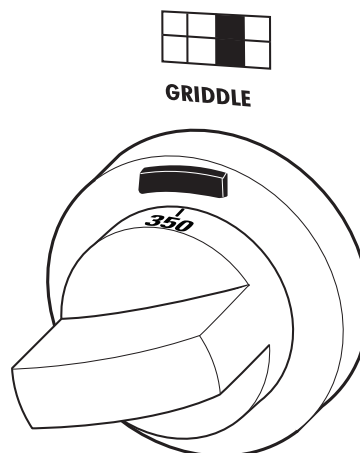

The griddle can be leveled. Remove the flue cover by lifting it straight up. The two inner screws are clamping screws for securing the griddle in place. Loosen these two screws before leveling. **Do not remove these two screws.**

The two outer screws are leveling screws. **Do not remove these two screws.** They can be turned to level the griddle or to provide a forward slope to help grease and oils to drain away from the food being cooked. After the first few uses, you will be able to judge the slope best suited for the foods you are cooking and personal preference.

After leveling the griddle, tighten the clamping screws to secure griddle in place. **Hand tighten screws; do not over-tighten.**

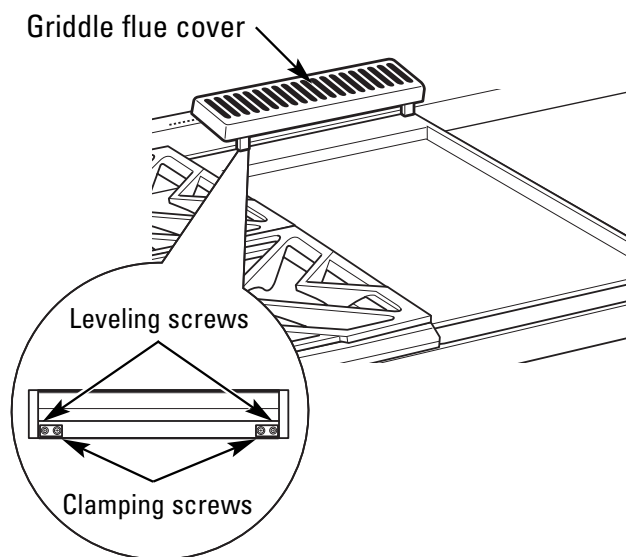

# Control Features - Range

## Design information

(Not all features are on all models. Appearance may vary.)

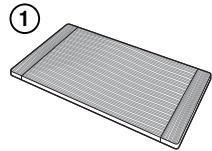

1 Bamboo Cutting Board

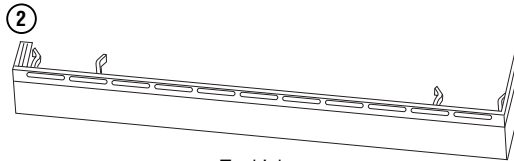

2 Toekick

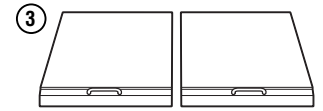

3 Grill and Griddle Covers

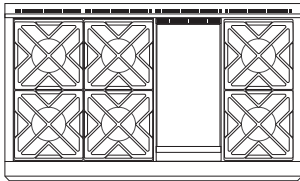

ZDP486NR, ZDP486LR—6 burners and grill  
ZDP486ND, ZDP486LD—6 burners and griddle

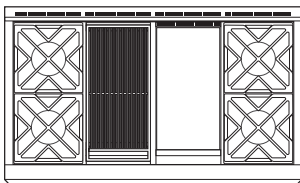

ZDP484NG, ZDP484LG  
4 burners, grill and griddle

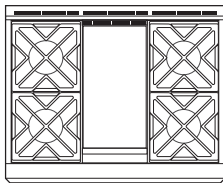

ZDP364NR, ZDP364LR—4 burners and grill  
ZDP364ND, ZDP364LD—4 burners and griddle

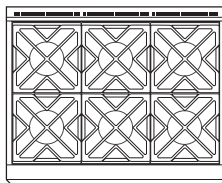

ZDP366N, ZDP366L  
6 gas burners

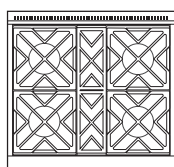

ZDP304N, ZDP304L

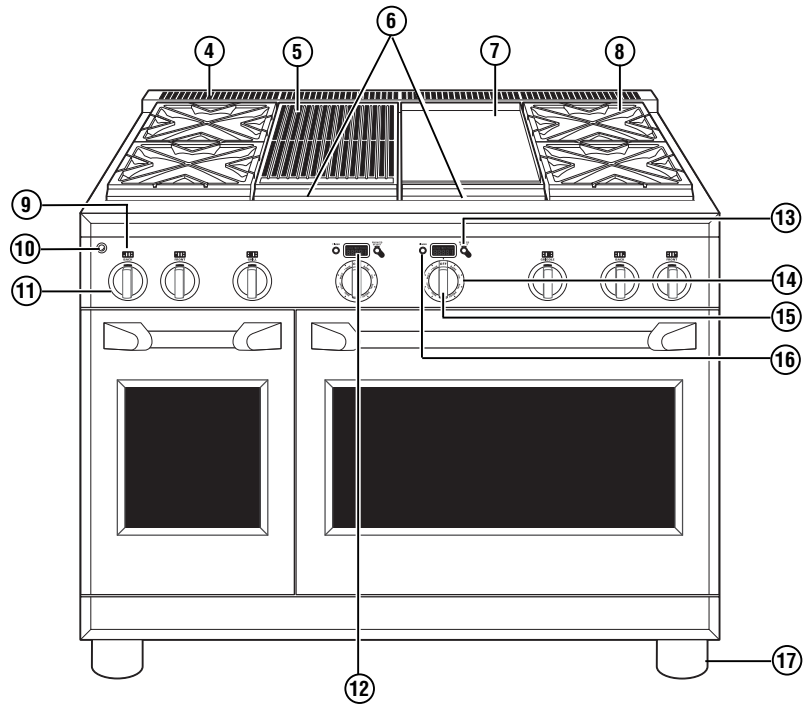

Number	Feature
1	Bamboo Cutting Board
2	Toekick
3	Grill and Griddle Covers
4	Oven Vents
5	IR (Infrared) Grill
6	Grill and Griddle Grease Troughs
7	Griddle
8	Cooktop Burner Grates
9	Burner Location Indicator
10	LED Bullnose Task Lighting Bezel
11	Burner Control Knob with Lighted Bezel
12	Oven Display
13	Mini-Knob (to select PROBE, TIMER, or Special Features)
14	Oven Mode Selector
15	Oven Temperature Knob
16	Kitchen Timer
17	Leveling System (4)

## Oven Control and Timer

**1. Oven Mode Selector** – Turn outer ring to select:

**PR OOF** – Maintains a warm environment useful for rising yeast-leavened products.

**BAKE** – Select for traditional baking.

**CONV BAKE** – Use for convection baking.

**CONV ROAST** – Use for convection roasting.

**CONV BROIL** – Use for convection broiling.

**BR OIL** – Select for broiling.

**CLEAN AN** – Select for the self-cleaning function. See the Self-Cleaning Oven section.

**2. Temperature Knob** – Turn to select: Temperatures from 175°F to 550°F.

**LOW BROIL** – A lower broiling temperature is automatically set.

**HIGH BROIL** – A higher broiling temperature is automatically set.

**CLEAN AN** – The self-clean temperature is automatically set.

**1. Mini-Knob** – Turn to select and push to enter PROBE or TIMER settings. Also to adjust CLEAN cycle time.

**2. Timer Button** – Push to select the kitchen timer function. The timer does not control oven operations.

**3. Oven Display** – Displays oven functions such as oven and probe temperatures and kitchen timer.

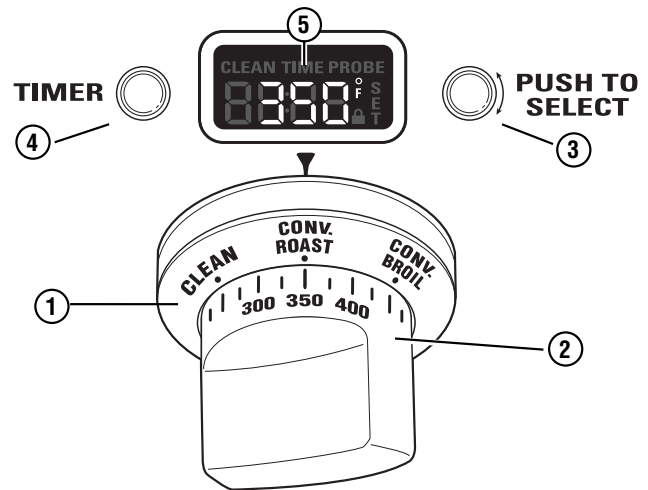

The Oven Mode Selector (1) AND the Temperature Knob (2) must be set together in one of the following valid pairings:

Oven Mode Selector	Temperature Knob
BAKE	175° to 550°F
CONV BAKE	175° to 550°F
CONVECTION/ROAST	175° to 550°F
CONVECTION/BROIL	HIGH or LOW BROIL
BROIL	HIGH or LOW BROIL
CLEAN	CLEAN
PROOF	---

**To cancel a feature, turn either the Oven Mode Selector or the Temperature knob to OFF.**

To cancel PROOF, turn the Oven Mode Selector to **OFF**.

## How to Set the Oven for Baking

1. Turn the Oven Mode Selector to **BAKE**.
2. Using the Temperature knob, set the desired temperature, in 25°F increments, from 175°F to 550°F.

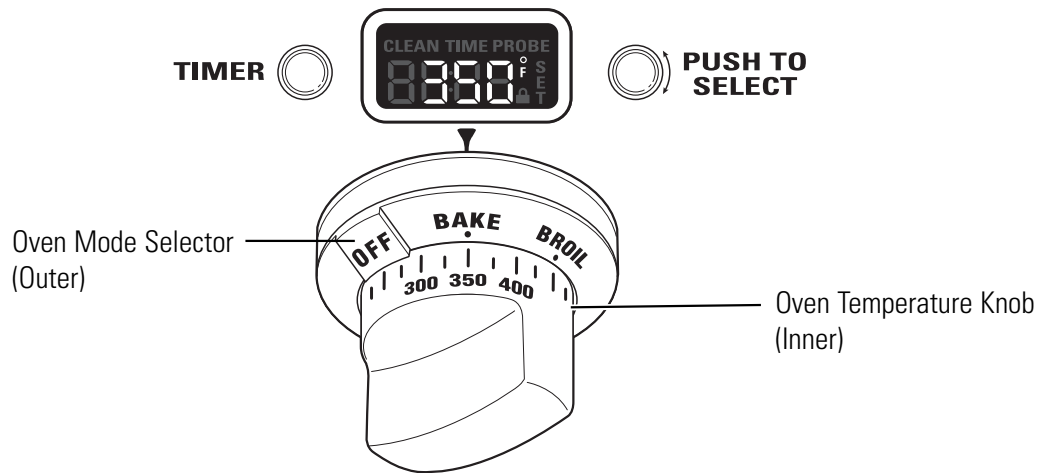

The oven will now begin to preheat. The temperature display will begin at 100°F and remain there until the oven exceeds that temperature. From that point, the display will show the actual temperature.

The interior lights will turn on and stay on until the oven is turned off. The convection oven fan will turn on temporarily during preheat. The control will beep when the oven is preheated and food can now be placed inside the oven.

3. Turn the Oven Mode Selector and the temperature knob to **OFF** when baking is finished.

**Note:** A cooling fan will turn on to cool internal parts. This is normal, and the fan may continue to run even after the oven is turned off.

Use the temperature probe when a precise internal temperature is important. See Owner's Manual.

## How to Set the Oven for Broiling and Convection Broiling

1. Turn the Oven Mode Selector to **BROIL** or **CONV BROIL**.
2. Turn the Oven Temperature Knob to **LO BROIL** or **HI BROIL**. **LO** or **HI** will appear in the display.

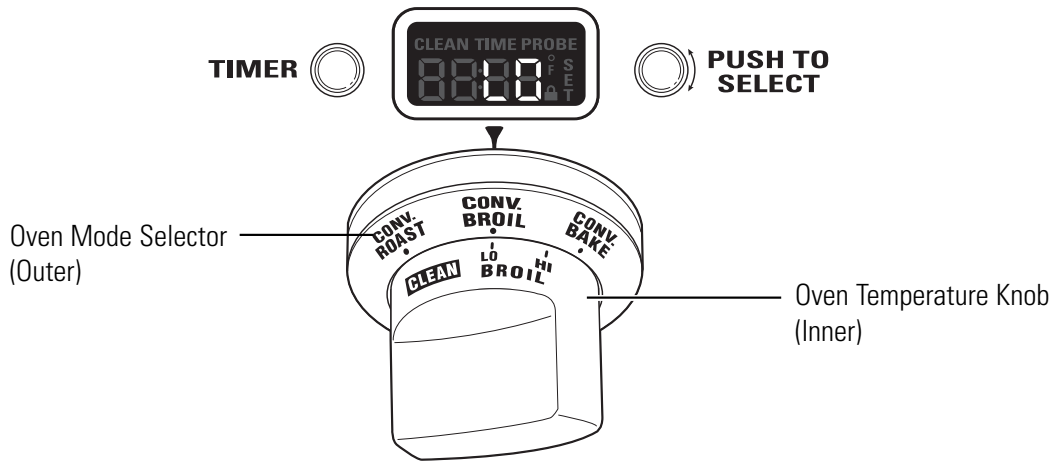

**Note:** Always broil with the door closed. If the door is left open, the display will scroll "CLOSE door" and the elements will not turn on until the door is shut.

The oven interior lights will turn on and stay on until the oven is turned off.

The convection fan will turn on when **CONV BROIL** is selected.

3. When broiling is finished, turn the Oven Mode Selector and the Temperature knob to **OFF**.

### **Note:**

- Broil will not work if the temperature probe is plugged in. Never leave your probe inside the oven during a broil cycle.
- A cooling fan will turn on to cool internal parts. This is normal, and the fan may continue to run even after the oven is turned off.

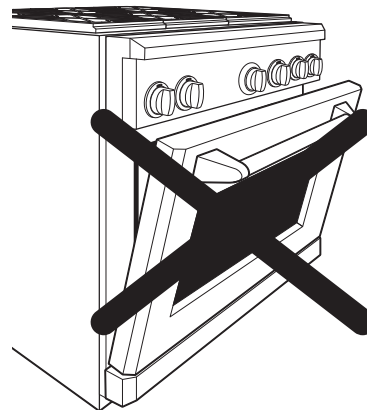

Open door broiling is not permitted.

The broiler does not need to be preheated for most broiling. However, foods that cook quickly, such as thin strips of meat or fish may require a short preheating period of approximately 5 minutes to allow the food to brown. Turn the food only once during broiling.

## Introduction to Convection Cooking

The Monogram reverse-air convection system consists of two dedicated heating elements wrapped around the convection fan. After preheating to the set temperature, all heat in CONV BAKE mode comes from these two dedicated elements. The convection fan periodically pauses, then changes direction to best distribute hot air throughout the oven. As a result, foods are evenly cooked and browned—often in less time with convection heat.

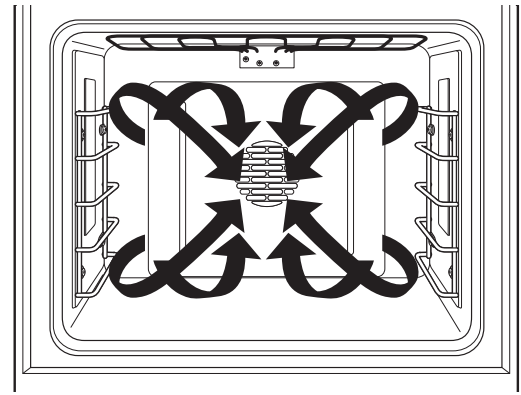

**Note:** The convection fan shuts off when the oven door is opened.

## How to Set the Oven for Convection Baking or Roasting

Convection Baking is ideal for evenly browned baked foods cooked on single or multiple racks. Select Convection Roast to roast large, tender cuts of meat uncovered.

When set on **CONV BAKE** or **CONV ROAST**, the rear convection elements and the fan operate when the oven is heating.

1. Turn the Oven Mode Selector to **CONV BAKE** or **CONV ROAST**.
2. Using the Temperature knob, set the desired temperature, in 25°F increments, from 175°F to 550°F.

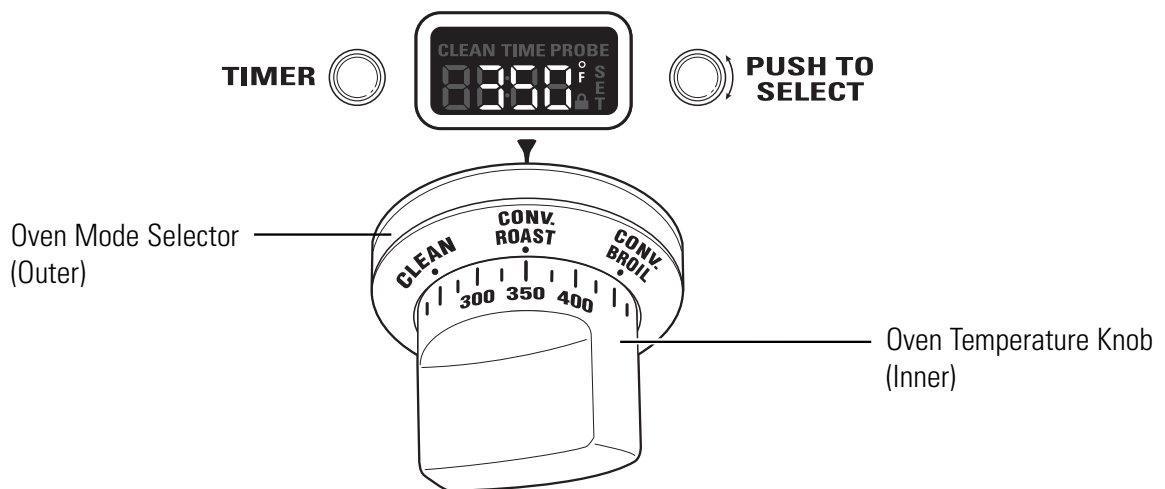

The oven will now begin to preheat. The temperature display will begin at 100°F and remain there until the oven exceeds that temperature. From that point, the display will show the actual temperature.

The interior lights will turn on and stay on until the oven is turned off. The convection oven fan will turn on during preheat. The control will beep when the oven is preheated and food can be placed inside the oven.

3. Turn the Oven Mode Selector and the Temperature knob to **OFF** when convection cooking is finished.

**Note:** A cooling fan will turn on to cool internal parts. This is normal, and the fan may continue to run even after the oven is turned off.

Use the temperature probe when a precise internal temperature is important. See Owner's Manual.

## How to Set the Oven for Proofing

The proofing feature maintains a warm environment which is useful for rising yeast-leavened dough.

1. Turn the Oven Mode Selector to **PROOF**. The display will show “PrF”. PROOF mode will not operate when oven is above 125°F. The display will scroll “too hot”. Allow the oven time to cool.

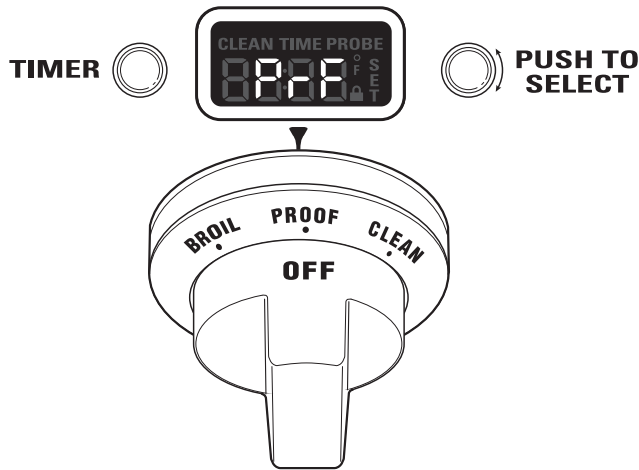

For best results, cover the dough with a cloth or with greased plastic wrap.

Use rack position B or C in the large oven. Use rack position B in the companion oven. See Owner's Manual.

The proofing feature automatically provides the optimum temperature (95°F) for the proofing process; therefore the Temperature knob does not affect the proof temperature.

The oven interior lights cycle on and off as necessary to maintain optimum proof temperature until the Oven Mode Selector has been turned to **OFF**.

- To avoid lowering the oven temperature and lengthening proofing time, do not open the oven door unnecessarily.
  - Check bread products early to avoid over-proofing.
2. When proofing is finished, turn the Oven Mode Selector to **OFF**.

## How to Set the Oven for Cleaning

**Caution:** See owner's Manual for Self-cleaning safety precautions.

1. Turn the Oven Mode Selector to **CLEAN**.
2. Turn the Temperature knob to **CLEAN**.

The control automatically defaults to the recommended clean cycle time of 5 hours. The clean time may be adjusted to any time between 3 and 5 hours using the Mini-Knob. The display will show the actual time remaining.

3. Push the Mini-Knob to start the CLEAN cycle. If “CLOSE door” scrolls in the display, the self-clean cycle has been selected but the door is not closed. Close the oven door.

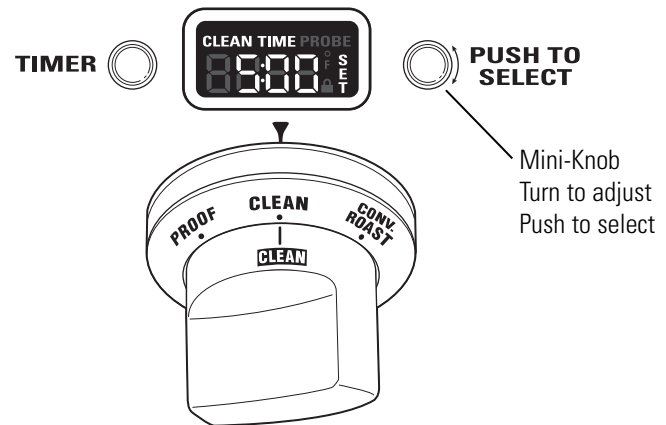

The  symbol will flash as the oven door is locked. It will not be possible to open the oven door during the clean cycle.

4. After the clean cycle is complete and the oven has cooled, “End” will show in the display and  the will turn off. Turn the Oven Mode Selector and the Temperature knob to **OFF**.

To interrupt a clean cycle, turn the Oven Mode Selector and the Temperature knob to **OFF**. When the oven has cooled to a safe temperature, the  symbol will turn off indicating the door may be opened.

An interrupted clean cycle cannot be restarted until after the oven is cool enough for the door to unlock.

## How to Set the Oven Timer

### Note:

- The timer is independent of all the other functions and does not control the oven.
- Although the electronic control has a timer, it does not have a clock feature.

### To set the timer:

1. Push the **TIMER** button.
2. Turn the **Mini-Knob** to adjust any length of time up to 12 hours and push to select it.

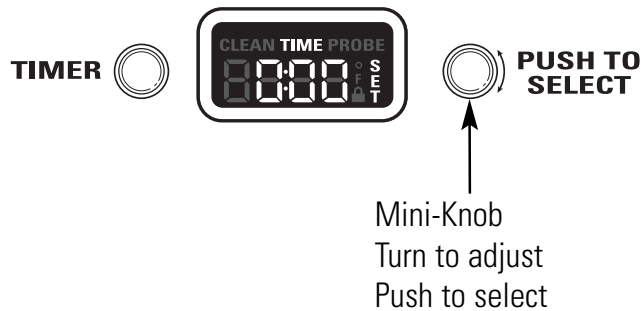

On double oven models, each oven control has its own timer function. Each timer can be set independently.

The control will beep with 1 minute remaining and the display will show seconds until the timer counts down to :00. When the timer reaches :00, the control will beep 3 times followed by one beep every 6 seconds until the Mini-Knob is pushed.

### To cancel the timer:

1. Push the **TIMER** button.
2. Turn the **Mini-Knob** to :00 and push to select.

### To adjust the timer after start:

1. Push the **TIMER** button.
2. Turn the **Mini-Knob** to a new desired time and push to select.

**Note:** The timer cannot be used while the oven is self-cleaning. (On double oven models, the timer for the oven that is not in the self-cleaning mode may be used.)

## Oven Thermostat Adjustment

You may find that your new oven cooks differently than the one it replaced. Use your new oven for a few weeks to become more familiar with it. If you still think your new oven is too hot or too cold, you can adjust the thermostat yourself.

On double oven models, use the main oven controls to enter the mode and to select the adjustment.

### To adjust the oven thermostat:

1. Push and hold the **TIMER** button and Mini-Knob at the same time for 4 seconds until the display shows "SF" (Special Features).



2. Turn the **Mini-Knob** counterclockwise until the display scrolls "OFFSEt". Push the **Mini-Knob** to select the offset mode.
3. Turn the **Mini-Knob** to adjust the oven thermostat up to 35°F hotter or (-) 35°F cooler in 1°F increments.
  - 3A. On double oven models, you can adjust the thermostat of the companion oven by turning the **Mini-Knob** above the companion oven. Use the main oven **Mini-Knob** to select that adjustment.
4. Push the **Mini-Knob** to select your choice and exit the mode. If you do not wish to save changes, push the **TIMER** button to exit at any time.

**Note:** This adjustment will only affect Bake, Convection Bake and Convection Roast temperatures; it does not affect broiling or self-cleaning temperatures. The adjustment will be retained in memory after a power failure.

Do not use thermometers, such as those found in grocery stores, to check the temperature setting of your oven. These thermometers may vary 20–40 degrees.

(Continued next page)

## Sabbath Mode\*

### To set the Sabbath mode:

The Sabbath mode is designed for use on the Jewish Sabbath and other Jewish holidays.



It can be used for baking only. It cannot be used for any other cooking mode.

When the Sabbath feature is set, the oven light and all audible beeps will be disabled. The feature will also provide a random delay period, of approximately 30 seconds to 1 minute, before the oven will turn on once it is set to **BAKE**.

1. Push and hold the **TIMER** button and **Mini-Knob** at the same time for 4 seconds until the display shows "SF" (Special Features).



2. Turn the **Mini-Knob** clockwise until the display scrolls "SAbbAtH." Push the **Mini-Knob** to select the Sabbath mode.
3. Once "SAbbAtH" is selected, the display will scroll "SAbbAtH ON".

The Sabbath setting will control both ovens. The symbol  will appear in both oven display windows indicating the Sabbath mode is set. The symbol  indicates the oven is overheating.

For double oven models, use the main oven control to set the Sabbath feature for both ovens.

### To Cancel the Sabbath Mode:

Repeat steps 1, 2 and 3. The display will scroll "SAbbAtH OFF".

The oven temperature may be adjusted at any time by turning the temperature knob. There is a random delay before the oven elements respond.



\*Certified Sabbath Mode

# Installation

Installation information is for reference only. See the Installation Instructions shipped with the product for complete details and before attempting to install the range or rangetop.

**Caution:** These ranges weigh up to 700 pounds. Some disassembly will reduce the weight considerably. Rangetops weigh up to 170 pounds. Due to the weight and size of the range or rangetop, and to reduce the risk of personal injury or damage to the product:

- TWO PEOPLE ARE REQUIRED FOR PROPER INSTALLATION OF 36" AND 30" RANGES AND 36" AND 48" RANGETOPS.
- THREE PEOPLE ARE REQUIRED FOR PROPER INSTALLATION OF 48" RANGES.

## Gas Supply Range and Rangetop

The natural gas models are designed to operate at 5" water column pressure. For proper operation, the pressure of the natural gas supplied to the regulator must be between 7" and 13" water column.

The LP models are designed to operate at 10" water column pressure. For proper operation, the pressure of the LP gas supplied to the regulator must be between 11" and 13" water column.

All models can be ordered to operate on NATURAL or LP gas. Models ordered to operate on NATURAL gas are shipped with an LP conversion kit. Models ordered to operate on LP gas are shipped with a NATURAL gas conversion kit.

**High Altitude Conversion Kit** - For operation above 6,000 feet, order Part #WB28K10553. This kit includes orifices for both LP and Natural gas operation.

A manual shut-off valve in the gas line (not provided), is to be installed in an easily accessible location. Make sure the homeowner knows where and how to shut off the gas supply to the range or rangetop.

## Range Electric Supply

These ranges must be supplied with 208/240 volt, 60 Hz., and connected to an individual, properly grounded branch circuit.

This branch circuit is to be protected by a circuit breaker or time delay fuse (50 amp for 48" ranges, 30 amp for 36" and 30" ranges).

The receptacle must be a NEMA 14-50R device to accept the 4-prong plug supplied with the range. If the electrical service provided does not meet the above specifications, it is recommended that a licensed electrician install an approved outlet.

## Rangetop Electric Supply

These rangetops must be supplied with 120 volt, 60 Hz., and connected to a dedicated, properly grounded branch circuit protected by a 15 amp circuit breaker or time delay fuse.

The power cord of this appliance is equipped with a three-prong (grounding) plug which mates with a standard three-prong grounding wall receptacle to minimize the possibility of shock hazard from this appliance.

If the electrical service provided does not meet the above specifications, it is recommended that a licensed electrician install an approved outlet.

## Backsplash Requirements

All models require 12" minimum clearance to a vertical combustible surface at the rear. In a range installation, if clearance is less than 12", the entire surface of the back wall above and the full width of the range must be protected by a backsplash. In a rangetop installation, if clearance is less than 12", the entire surface of the back wall above the countertop and the full width of the rangetop must be protected by a backsplash. The backsplash must be constructed of non-combustible material, such as metal, ceramic tile, brick, marble or other stone.

**WARNING:** Installations without a hood require 48" minimum to combustibles. A custom hood installation with exposed horizontal combustible surfaces must have an Auto-On feature. Refer to hood installation instructions for specific hood clearances.

## Leveling the Range

### WARNING:

- All ranges can tip. Injury could result. Install the supplied Anti-Tip Bracket. See the instructions included with the bracket.
- The range must be level and be supported by the legs—not the wheels. The range could move if the wheels make contact with the floor. Be sure all legs make contact with the floor in any installation.

### Note:

- All legs must be leveled after the product is installed.
- Check to be sure the adjoining cabinets/ countertops are level, front to back and left to right across the opening of the range.
- Measure the distance from the floor to the top of the countertop in the left and right rear corners.
- Adjust the height of the range to countertop height or higher.

**IMPORTANT:** This range should always be installed at countertop height or higher. **DO NOT INSTALL THE RANGE LOWER THAN ADJACENT COUNTERTOP HEIGHT.** The range must be supported by all 4 legs, regardless of countertop height.

### Front leg adjustment:

**Note:** If toe kick is installed, pull to remove for access to front leveling legs.

1. Slide front cylinders up to adjust front leveling legs. Be careful not to damage cylinder.
2. A leveling leg wrench is supplied. Reach under the front of the range near the right side. Locate and remove a thumb screw, then slide wrench out of the slot.

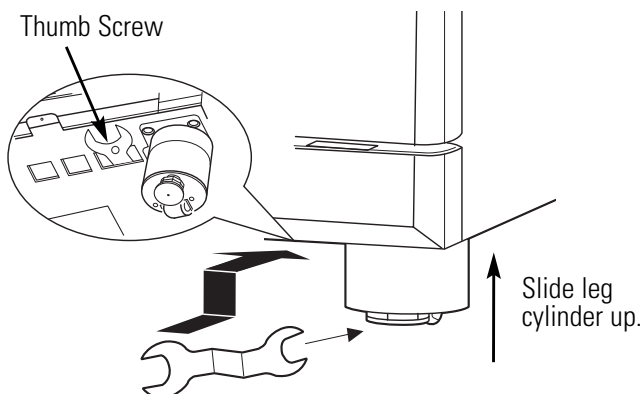

3. Use the supplied wrench to turn the front leveling legs. Turn clockwise to raise the range above the wheels. Turn counterclockwise to lower the legs.
4. Be sure to return the wrench to its storage slot for future use.

### Rear leg adjustment:

1. Remove two screws from rear vent trim. Slide vent trim forward, then lift up to remove.
2. Find the two rear leg extension rods. Use a 1/4-in. driver or wrench to adjust the left or right rear legs.

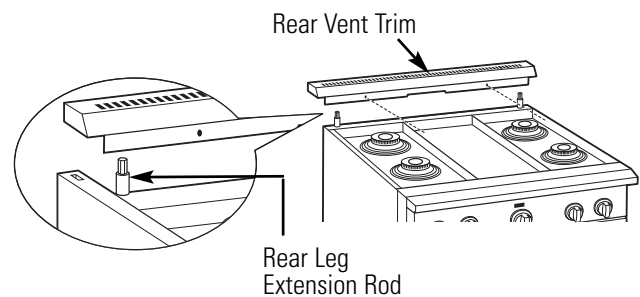

3. Replace the rear vent trim using the original screws.

## Range Toekick

A toe kick, that clips around the front leveling legs, is supplied with each range. Customer use of the toe kick is optional.

The toekick is installed after the range has been leveled.

### Toekick installation:

1. Measure the distance between the floor and the bottom of range.
2. Loosen the two screws on each end. Adjust the toekick height by sliding the upper and lower pieces apart to 1/8" less than the measured height.

(Continued next page)

- Secure the top and bottom sections by tightening the 2 screws on each end.

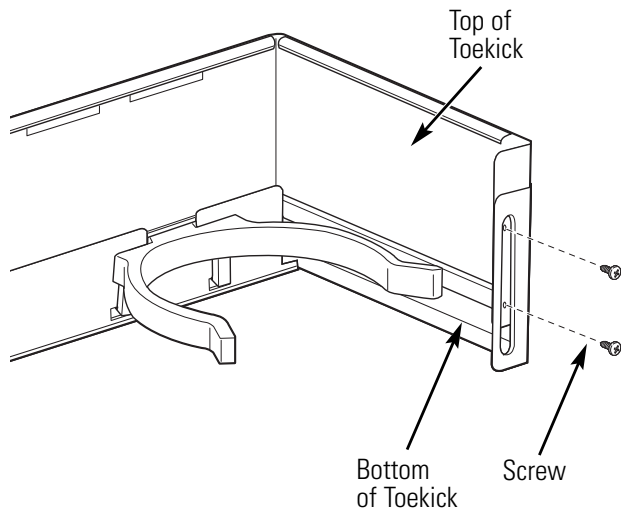

- Push toekick against range leg until clip snaps to legs.

**Note:** Be sure the toekick snaps securely to the leg.

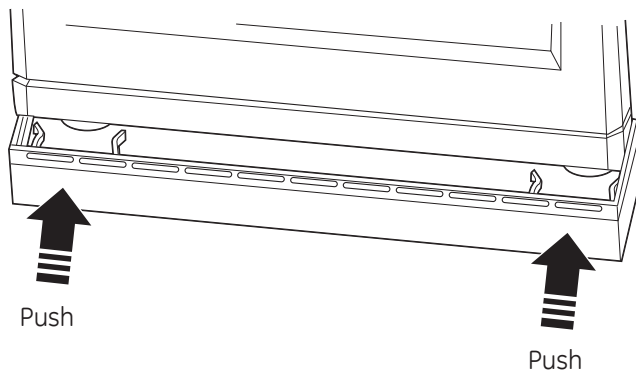

### Rangetop Anti-Slide Bracket

**WARNING:** All rangetops can slide out. Injury could result. When properly installed, a hold-down strap with screws secures the rangetop to the rear or side cabinet walls. See the instructions included with the bracket.

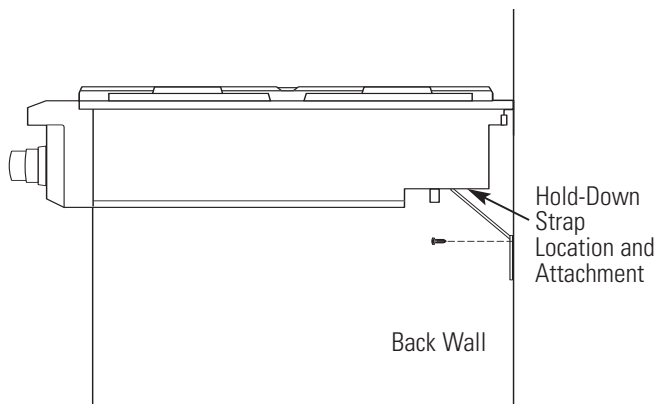

### Range Anti-Tip Device

**WARNING:** All ranges can tip. BURNS or other SERIOUS INJURIES can result. INSTALL and CHECK the ANTI-TIP bracket following these instructions.

To reduce the risk of tipping the range, the range must be secured by a properly installed anti-tip bracket. See installation instructions shipped with the bracket for complete details before attempting to install.

To check if the bracket is installed and engaged properly, carefully tip the range forward. The bracket should stop the range within 4 inches. If it does not, the bracket must be reinstalled.

If the range is pulled from the wall for any reason, always repeat this procedure to verify the range is properly secured by the anti-tip bracket.

If your range has no anti-tip bracket, call 1.800.626.8774 to receive one at no cost.

If the Anti-Tip device supplied with the range does not fit this application, use the universal Anti-Tip device WB2X7909.

Read the AHAM Anti-Tip Safety Brochure packed with the bracket.

### Anti-Tip Parts Provided

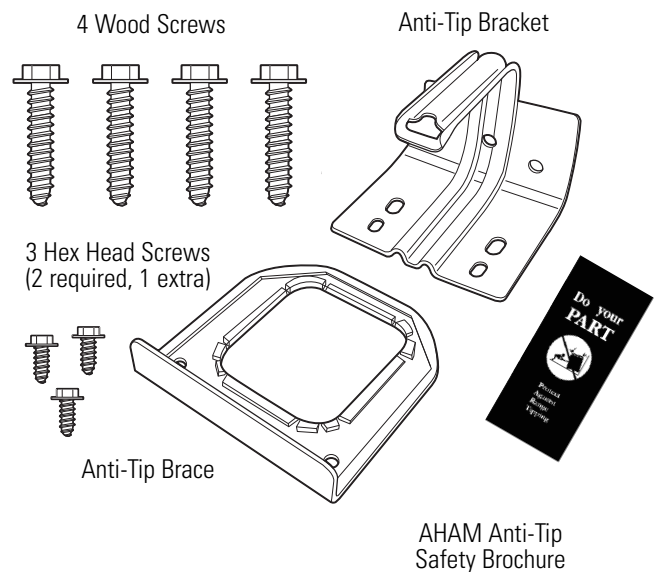

AHAM Anti-Tip Safety Brochure

Attach the Anti-Tip Brace onto the bottom of the range in the recessed area. Install 2 hex screws (provided) through the brace and into the range.

**Note:** This Anti-Tip device may be installed on the opposite side of the range.

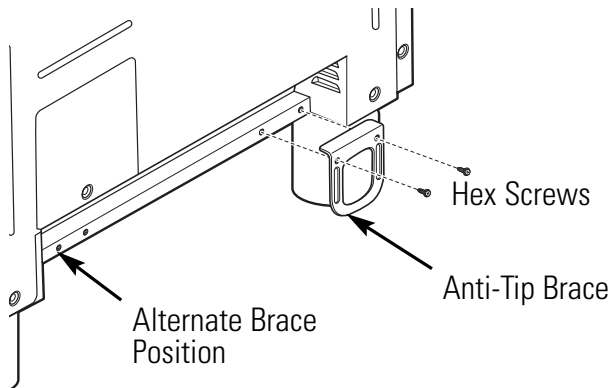

1. Measure and mark Dimension A (see table below) from the left (or right) side of the installation location. If the countertop has an overhang, add that dimension to Dimension A.
2. Place the Anti-Tip Bracket against the floor and back wall at the marked location. Mark screw holes for fastening the bracket to the wall sole plate and the floor.
3. Drill 1/8" pilot holes at a 20° angle.
4. Secure the bracket to the wall and/or floor with at least 2 wood screws (provided).

**For Concrete or Cement Construction:** You must use appropriate fastening hardware (not provided).

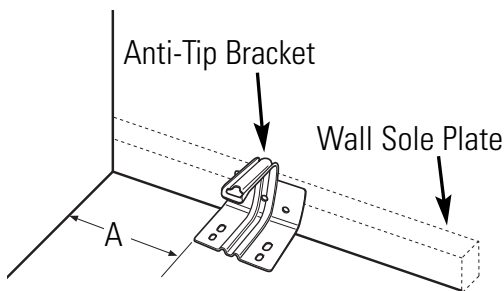

Range	A
30"	5-1/16"
36"	5-1/16"
48"	8-1/4"

## Gas Conversion Range and Rangetop

**⚠ WARNING:** This conversion must be performed by a qualified installer or gas supplier in accordance with the manufacturer's instructions and all codes and requirements of the authority having jurisdiction. Failure to follow instructions could result in serious injury or property damage. The qualified agency performing this work assumes responsibility for the conversion.

**⚠ WARNING:** The rangetop, as shipped from the factory, is set for use with its intended gas. If you wish to use your rangetop with the alternate gas, you must first replace the orifices and convert the pressure regulator.

**⚠ WARNING:** The following adjustments must be made before turning on the burner. Failure to do so could result in serious injury. Be sure pressure regulator has been converted as described in Step 2.

### TOOLS YOU NEEDED FOR CONVERSION

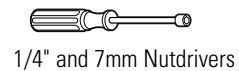

### 1 ORIFICE HOLDER

The range orifice holder is located behind the front access panel at the bottom of the range.

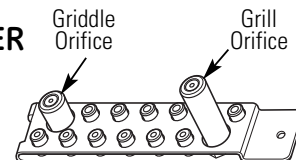

The rangetop orifice holder is located inside the range insulation cover.

Burner Orifices

Additional orifices may be present. Use only the orifices specified in the instructions for your range or rangetop.

## 2 CONVERT THE REGULATOR

**Disconnect all electrical power at the main circuit breaker or fuse box.**

- A. Remove the rear vent trim (on ranges only) to access the regulator. The Rangetop regulator is on the left bottom corner.

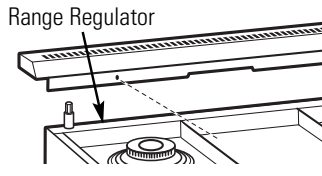

- B. Shut off the gas supply by closing the manual shut-off valve in the unit or at the wall.
- C. Convert the pressure regulator:
- Unscrew the cap with plunger.
  - Place your thumb against flat side of the plunger and press down to snap the plunger out of the cap.
  - Carefully look at the plunger to locate the NAT or LP position.

- Turn the plunger over so that the desired gas is showing near the bottom.

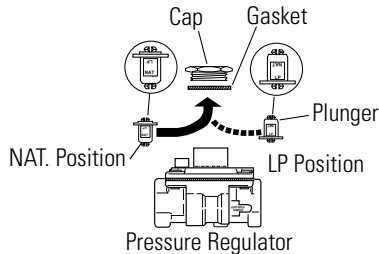

- Snap the plunger back into the cap.
- Screw the cap back onto the regulator.

## 3 CHANGE BURNER ORIFICES

**INSTALLATION TIP:** First remove all orifices and then start replacing them. This will help to prevent the possibility that some may not be replaced.

- A. Remove the burner grates, burner caps and burner heads.
- B. Loosen the top burner orifices using a 7 mm nut driver. Use small pliers to carefully lift out the orifices.

Burner Cap



Burner Head

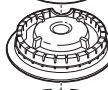

Spark Igniter



Burner Base



The main orifice is located low in the center of the burner, while the simmer orifice is located higher beside the center of the burner.

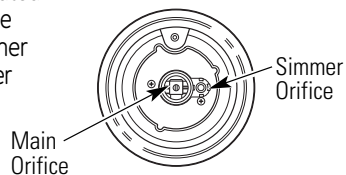

## 3 CHANGE BURNER ORIFICES (cont.)

**IMPORTANT:** Find your model number below. Read each orifice label to identify and install them in the exact locations shown.

### ZDP304 SIMMER ORIFICES

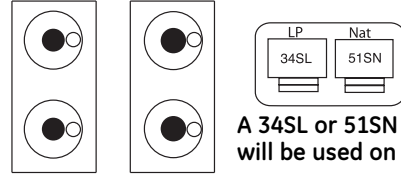

A 34SL or 51SN orifice will be used on all burners.

### ZDP304 MAIN ORIFICES

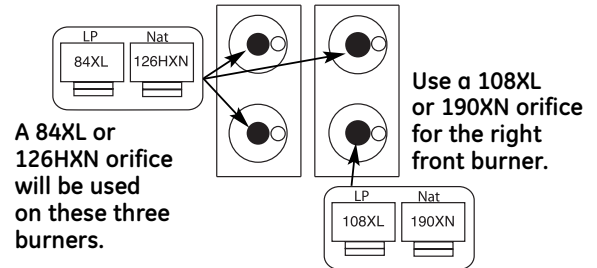

A 84XL or 126HXN orifice will be used on these three burners.

Use a 108XL or 190XN orifice for the right front burner.

### ZDP364, ZDP366, ZDP484, ZDP486

#### SIMMER ORIFICES

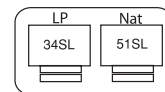

A 34SL or 51SN orifice will be used on all burners.

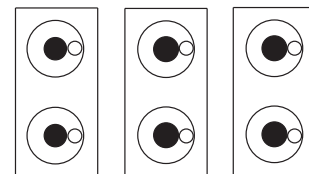

#### MAIN ORIFICES

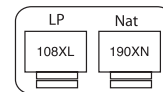

Use 108XL or 190XN orifices for all burners.

- A. Return the unused orifices to the holder. Reattach the holder and the instruction sheet with screw in the original storage location.
- B. Replace the burner heads, caps and top grates. On range models, replace rear vent trim.

#### 4 CHANGE GRILL ORIFICE (if present)

Locate the 1-1/2" long Grill orifice.  
Select for your gas type. LP—.047, NAT—.067



- A. Remove the grill cover, grates and grate frame. Lift the radiant baffle straight up and off.

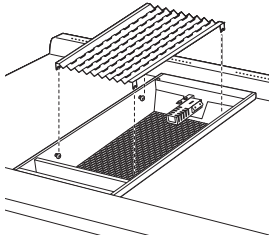

- B. Remove the 2 hex head screws from the top of the igniter.
- Remove one screw from each side of the burner surround.
  - Lift out the surround.

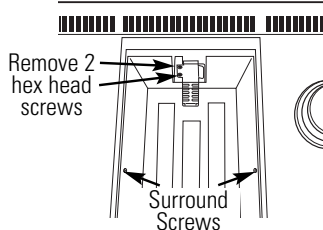

- C. Carefully push the igniter aside and under the burner. Do not pull or pinch the wire.

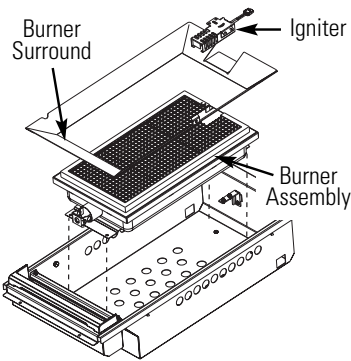

Remove 4 burner attachment screws, 2 at the front and 2 at the back. Slide the burner assembly toward the back and out of the gas inlet.

- D. Use a 1/2" deep well socket to remove and replace the orifice. Reverse these steps to re-assemble the grill. Be sure to place the unused orifice in the holder for possible future use.

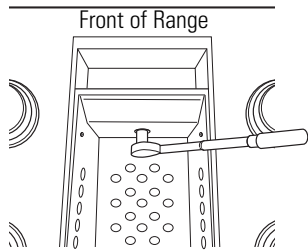

#### 5 CHANGE GRIDDLE ORIFICE (if present)

Locate the 3/4" long Griddle orifice.  
Select for your gas type. LP—.047, NAT—.076



- A. Lift off the griddle flue cover. Remove the 2 inside clamping screws.

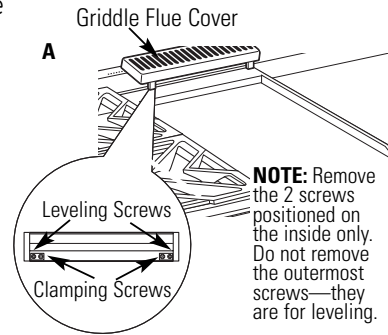

**NOTE:** Remove the 2 screws positioned on the inside only. Do not remove the outermost screws—they are for leveling.

- B. Use a pad or piece of carton to protect the adjacent surface. Slide the griddle toward the rear and out of the hold-down tabs along the bottom.

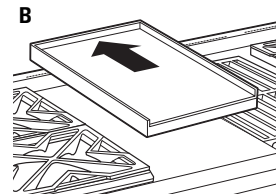

- C. CAREFULLY lift and hold the griddle. A thermostat capillary is routed through a clip. Gently lift the griddle to one side and slip the capillary out of the clip.

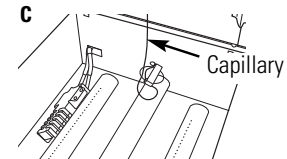

- D. Lay the griddle on the padded surface. Do not disconnect or pull on the capillary.

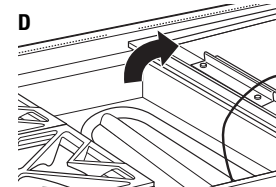

- E. Remove the 2 burner hold-down screws at the rear of the burner.
- Pull the burner straight back toward the rear and out of the gas inlet.

- F. Use a 1/2" deep well socket to remove and replace the orifice.

E Back of Range

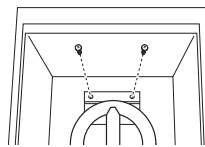

F Front of Range

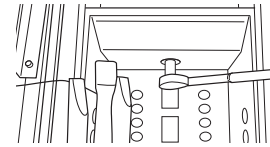

Reverse these steps to re-assemble the griddle. Push excess capillary back into the entry hole. Route the thermostat capillary so it is held by the clip. Place the unused orifice in the holder for possible future use.

## 6 ADJUST BURNER FLAMES

Normally, burners do not need further adjustment. Make adjustments only when necessary.

- A. Turn on the gas. Plug in electrical cord.
- B. Turn all burners on highest setting and check the flames. They should be blue in color. When using LP gas, the flames may have some yellow tipping at the ends of the flame. Foreign particles in the gas line may cause an orange flame at first, but this will soon disappear.
- C. Turn the burner knob to "LO" while observing the flame.

### Adjust the setting of the upper row of flames using the valve bypass screw as follows:

Adjustments must be made with two other burners in operation on a medium setting. This prevents the upper row of flames from being set too low, resulting in the flame being extinguished when other burners are turned on.

- D. To adjust the flame, remove the knobs. Insert a small flat-blade screwdriver into the hole in the center of the valve stem to engage screw.

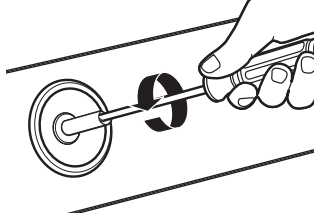

- If the flames are too small or flutter, turn the screw counterclockwise.

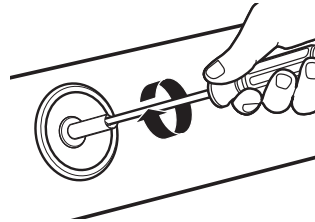

- If the flames are too large, turn the screw clockwise.
- E. Make the adjustment by slowly turning the screw until flame appearance is correct.

**Note:** Once the conversion is complete and checked, fill out the conversion label and affix the label near the rating label. For ranges, place the label beneath the control panel. For rangetops, place the label on the bottom of the unit.

## Oven Operational Notes

Certain modes, when selected, will automatically enter into a preheat. The temperature knob is used to set the desired temperature, in 25°F increments, from 175°F to 550°F. The oven will now begin to preheat. The temperature display will begin at 100°F and remain there until the oven exceeds that temperature. From that point, the display will show the actual temperature.

The interior lights will turn on and stay on until the oven is turned off. The convection oven fan will turn on temporarily during preheat. The control will beep when the oven is preheated and food can be placed inside the oven.

**Note:** A cooling fan will turn on to cool internal parts. This is normal, and the fan may continue to run even after the oven is turned off.

Preheat Chart

Mode	Preheat
Proof	No
Bake	Yes
Convection Bake	Yes
Convection Roast	Yes
Convection Broil	No
Std Broil	No
Clean	No
Sabbath Mode	No
Probe Usage	Yes

- Preheat operation consists of multiple phases, which are time and/or temperature dependant. Each phase of preheat utilizes combinations of inner and outer bake, broil, and inner convection elements. For example, one phase may use inner convection and outer broil simultaneously. Another phase may use inner broil and outer bake simultaneously.
- At the start of Preheat, the convection fan will delay running for 10 seconds. It will then run CCW with no directional changes for the remainder of Preheat.

- The convection fan will cycle on and off while cooking to best distribute hot air in the oven. The convection fan shuts off when the oven door is opened.
- Different broil elements are used in each broil mode. There are 2 different broil modes, each providing a HI and a LO setting.
- The Convection Broil mode uses both the inside and outside broil elements and convection fan.
- Broil will not work if the temperature probe is plugged in.
- When using the probe, you can use the timer, but you cannot use timed oven operations.
- In Convection Bake, both the inner and the outer convection elements cycle and the fan operates whenever the oven is heating.
- Convection Broil will not work if the temperature probe is plugged in. Never leave your probe inside the oven during a broil cycle.
- The Clean cycle can be set for a minimum of 3 hours and a maximum of 5 hours. The default setting is 5 hours. The 5-hour set time consists of 4 hours and 15 minutes of cleaning and 45 minutes of cool down. The door will unlock at an approximate temperature of 450°F.
- On double oven models, the ovens can be set to self clean in sequence. The first oven set starts the cycle. The second oven will start cleaning as soon as the first oven has cooled to 550°F (it should already be below 550°F at the end of a standard 5-hour clean since a 45 cool-down is included in the time). If the first oven clean cycle is cancelled, the second oven will start cleaning immediately or as soon as the first oven cools below 550°F.
- Self-Clean will not work if the temperature probe is plugged in or if the Sabbath feature is set.
- Proofing will not operate when oven is above 125°F. The display will show "too hot". Allow the oven time to cool.

# Component Locator Views

Front of Range (48-in. range shown)

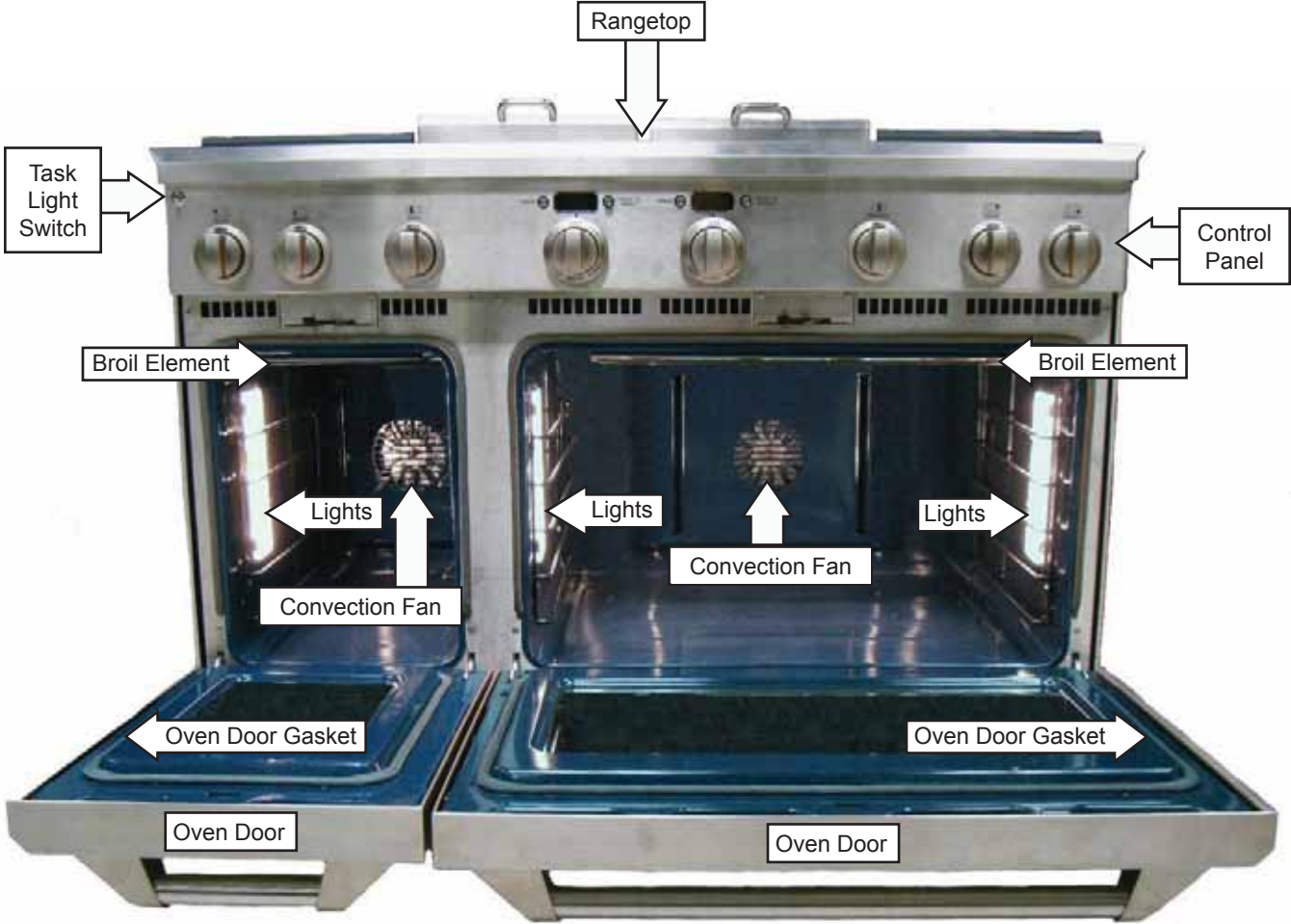

Rear of Range (48-in. range shown)

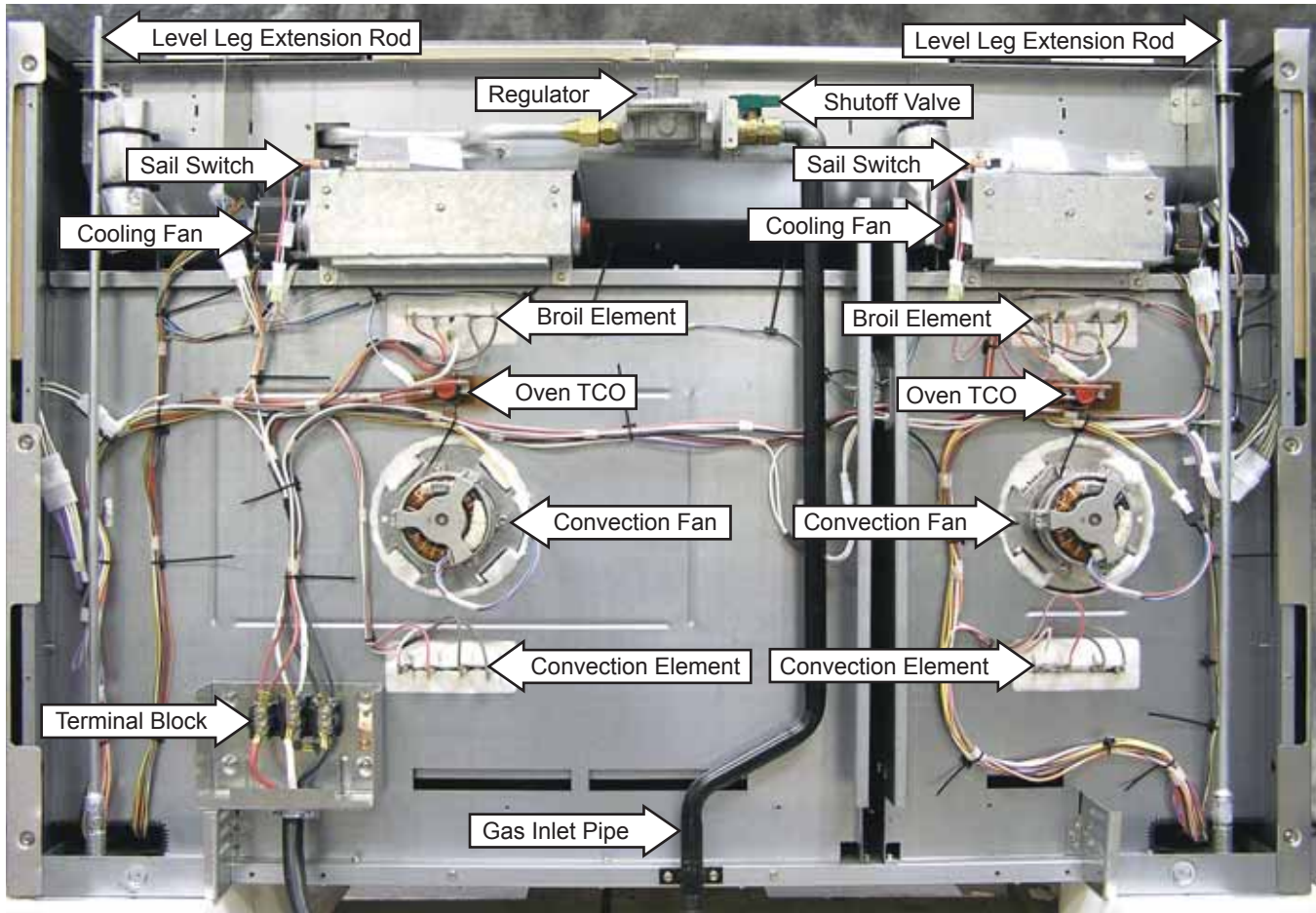

# Rangetop ZGU484NG

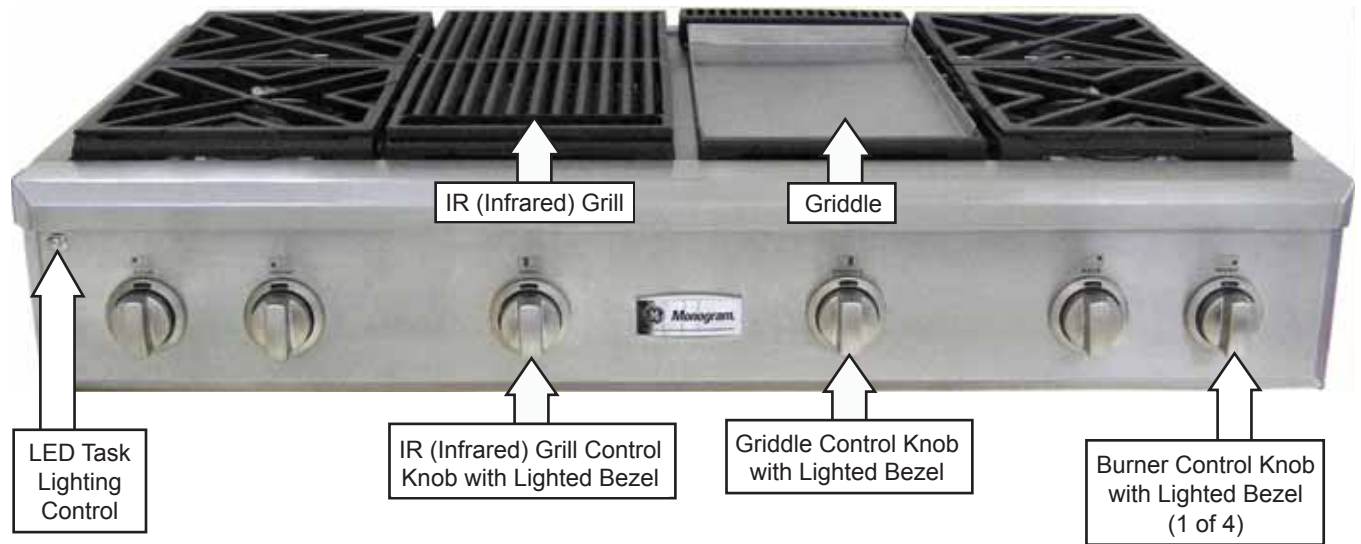

## Rangetop ZGU484NG (burner pans, top heat barriers, grill, and griddle removed)

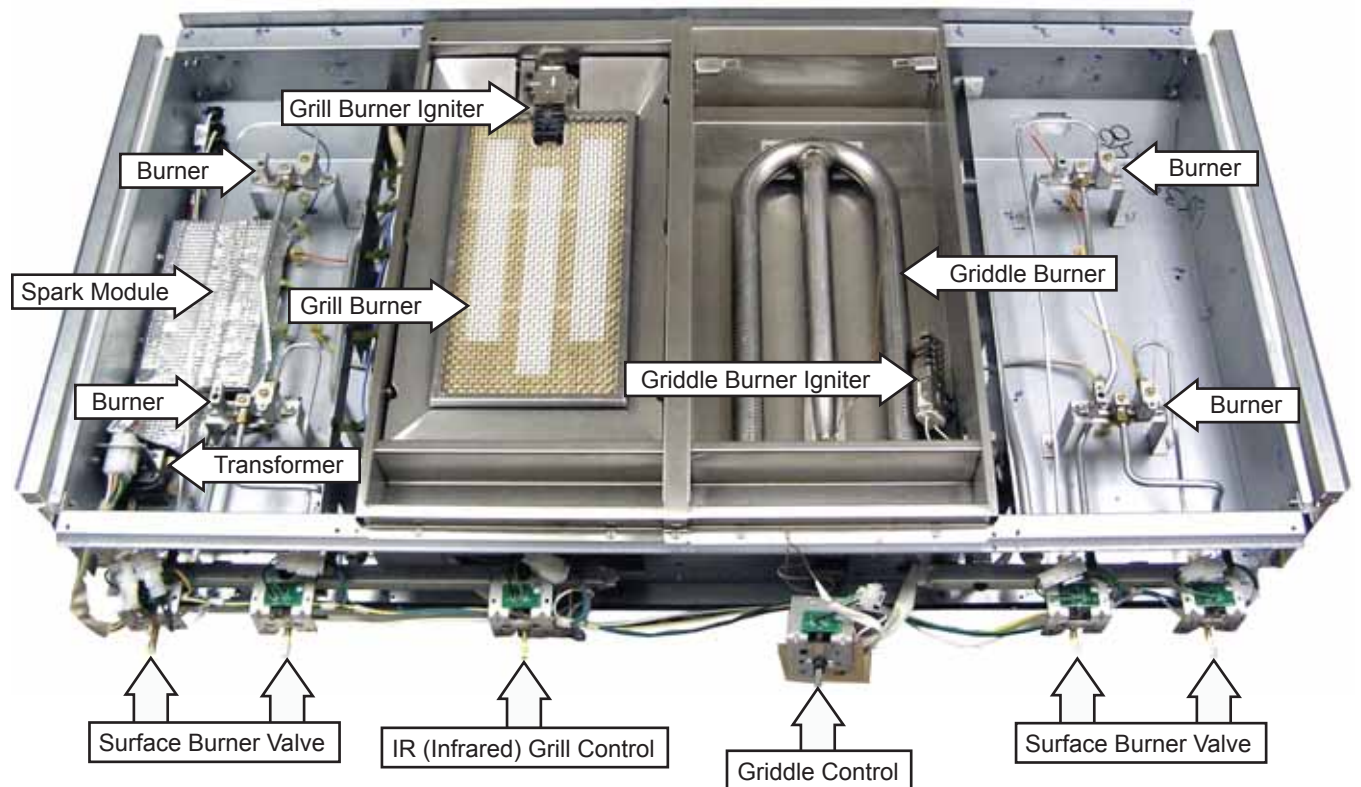

# Surface Components

**WARNING:** Sharp edges may be exposed when servicing. Use caution to avoid injury. Wear Kevlar gloves or equivalent protection.

## Control Panel

It is necessary to remove the control panel from the range or rangetop chassis and place it in the service position to access certain components.

**To place the control panel in the service position:**

**Note:** It will be necessary to pull the rangetop approximately 10 inches out from its installation.

1. Remove left and right side grates, surface burner knobs, grill and griddle control knobs.
2. On range models:
  - a. Remove the 2 Phillips-head screws that attach the griddle control bezel to the control panel.
  - b. Remove the 2 Phillips-head screws that attach the griddle control to the manifold bracket.

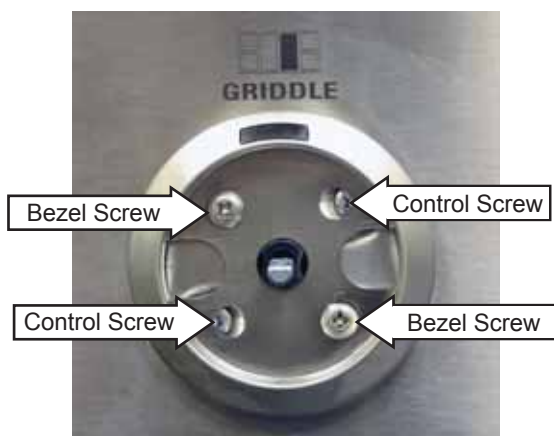

3. Remove the 2 Phillips-head screws within each bezel that attach the bezel to the manifold brackets.

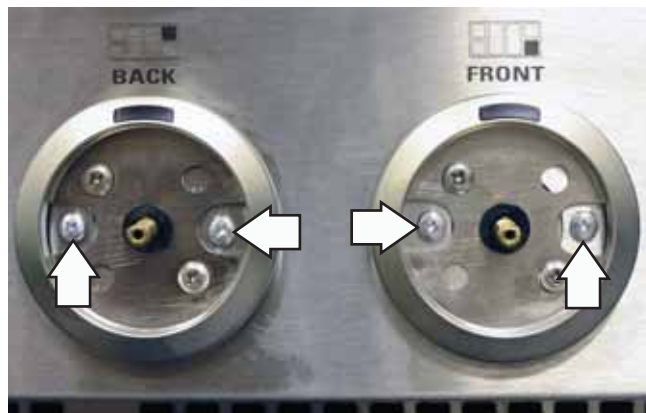

4. Remove the T-15 Torx screws from the bottom of the control panel.
5. Remove the Phillips-head screw at each front corner that attaches the front of the side trim to the control panel.



### Note:

- A ground wire at each end of the panel allows the panel to be lowered without falling.
- Before lowering, protect the bottom of the front panel from scratches caused by the lock motor arm (range models) or front frame edge.
- If the range has a grill, use caution when lowering the control panel to prevent damage to the switches mounted at the bottom of the grill valve.

6. On rangetops, remove the two 1/4-in. hex-head screws and the Phillips-head screw (on each side), from the back of the control panel flange.

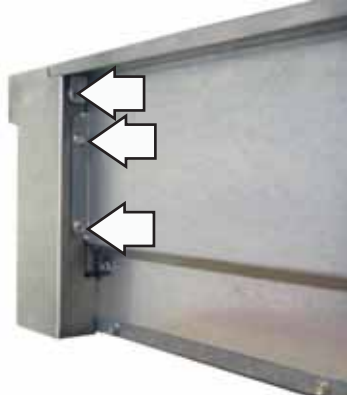

7. Pull the control panel straight out from the chassis, then carefully lower the control panel onto a protective, supportive surface.



Rangetop Control Panel in Service Position

## Grill Assembly

**Note:** The following describes the procedure to remove the grill assembly.

### To remove the grill:

1. Lift off the grill grate and grill frame.
2. Lift the grill baffle straight up and remove it from the 4 support posts located on the side walls. (See **Control Features - Rangetop.**)
3. Remove the two 1/4-in. hex-head screws that attach the igniter to the igniter bracket, then place the igniter aside.
4. Remove the 2 Phillips-head screws that hold the reflector trim in place.
5. Lift up and remove the trim and screen.

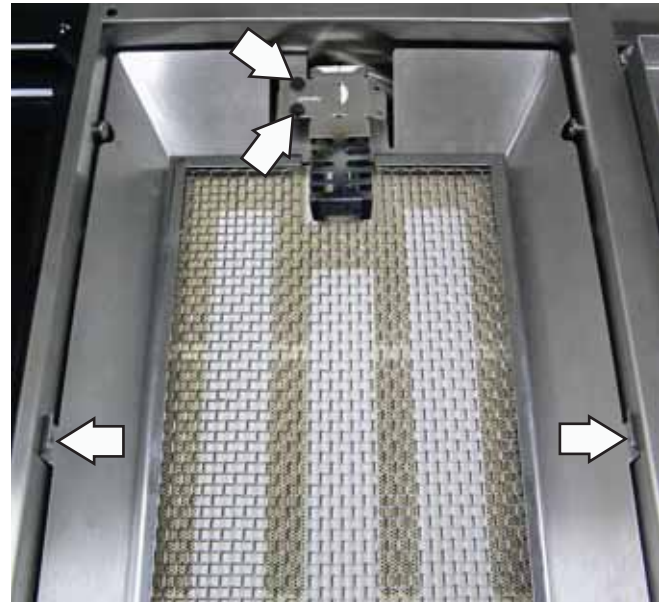

- Remove the two 1/4-in. hex-head screws from the front and the two 1/4-in. hex-head screws from the rear of the grill burner.

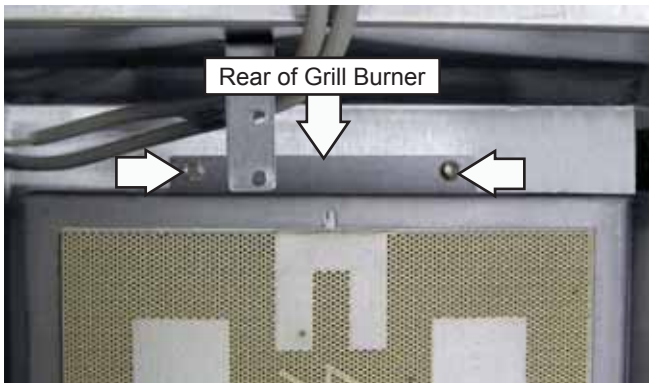
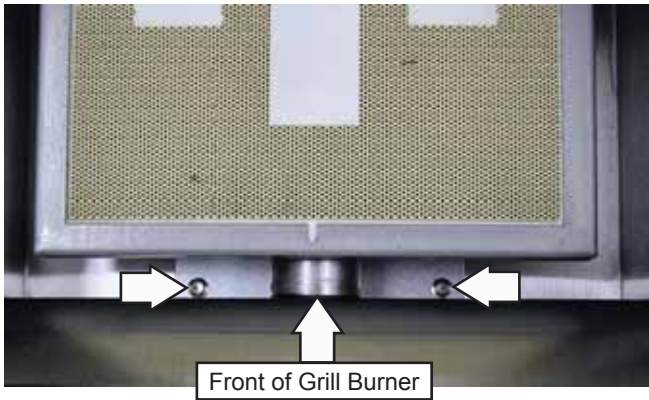

- Lift up and maneuver the grill burner past the igniter bracket.

#### Grill Burner Removed



- Remove the grill burner igniter. (See **Grill Burner Igniter.**)
- Place the control panel in the service position. (See **Control Panel.**)
- Remove the 2 Phillips-head screws and the center trim, if applicable.
- Remove the 2 Phillips-head screws from the front and the 2 Phillips-head screws from the rear of the grill burner box.



Rear of Grill Burner Box

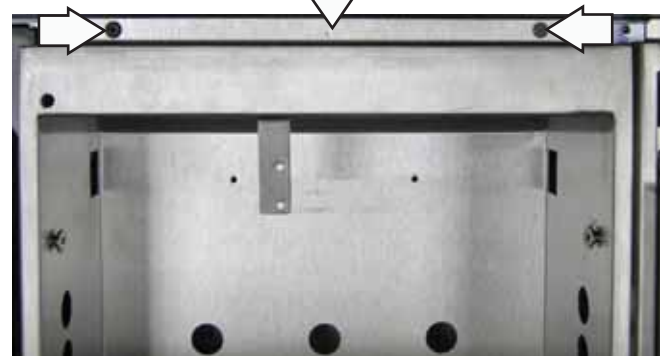

- Lift up and remove the grill burner box.

## Grill Burner Igniter

**Note:** The following describes the procedure to remove the grill burner igniter. The grill igniter has a resistance value of 45 to 400  $\Omega$  at room temperature.

### To remove the grill burner igniter:

1. Remove the grill burner. (See **Grill Assembly**.)

**Note:** In the following step, ensure that the spring clip is captured and retained inside the grill burner box.

2. Squeeze the ends of the spring clip and retract the clip from the harness access cutout on the left side of the grill burner box.

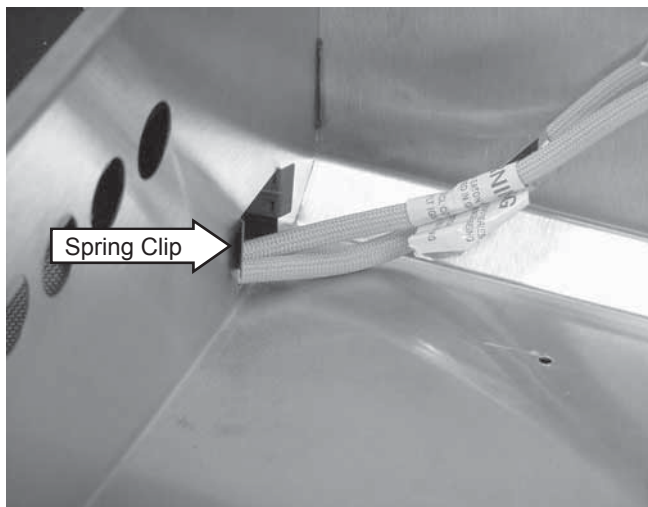

3. Pull the harness connector thru the cutout and disconnect the igniter wire harness.

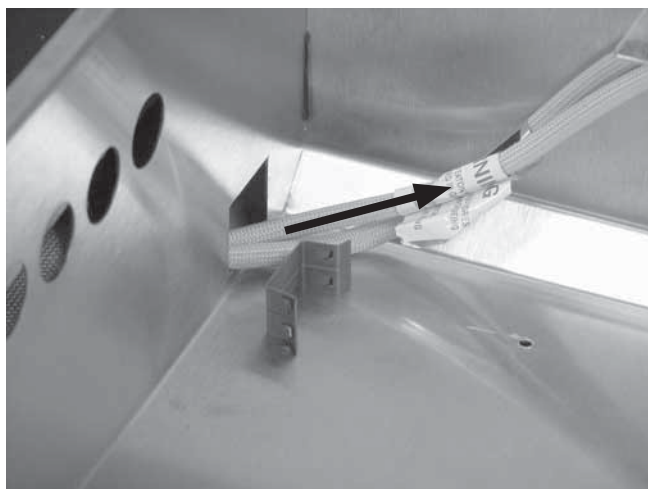

## Grill Safety Valve

**Note:** The following describes the procedure to remove the grill safety valve. The grill safety valve has a resistance value of 1  $\Omega$  or less.

### To remove the grill safety valve:

1. Remove the grill assembly. (See **Grill Assembly**.)
2. Remove the two 1/4-in. hex-head screws that attach the heat shield.

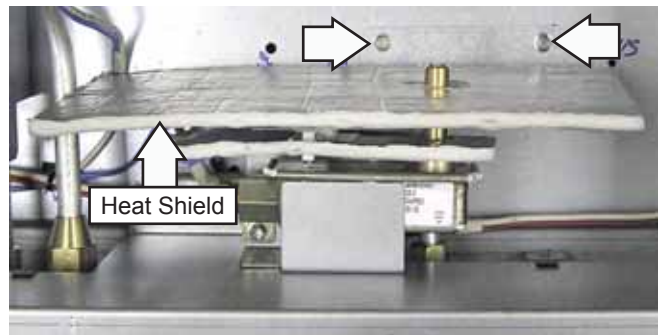

3. Disconnect the wires from the valve.
4. Remove the heat barrier.

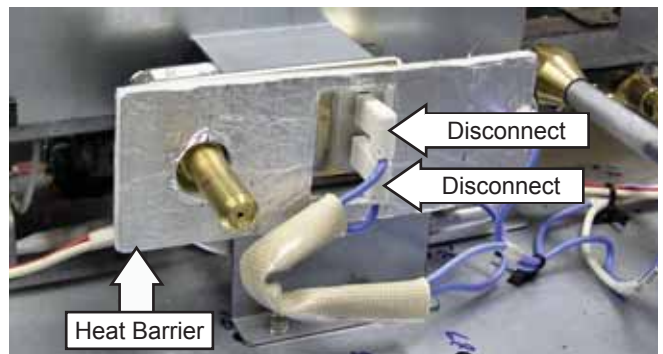

5. Remove the 9/16-in. nut from the valve.
6. Remove the 1/4-in. hex-head screw that attaches the valve to the valve bracket and separate the valve from the gas tube and valve bracket.

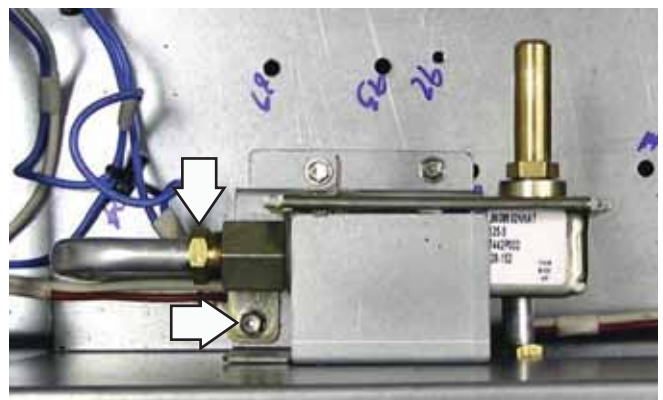

## Grill Control

The grill control is attached to the manifold bracket. A switch bracket is attached to the control and secures 2 switches. The front switch controls the igniter and the rear switch controls the LED indicator. When the Grill knob is turned to the ON position, both switches close contacts. Both switches can be replaced separately.

### To remove the grill control switches:

1. Place the control panel in the service position. (See **Control Panel**.)
2. Carefully press the 2 locking tabs away from the switches and remove the switches from the switch bracket.
3. Mark and disconnect the wires from the 2 switches.

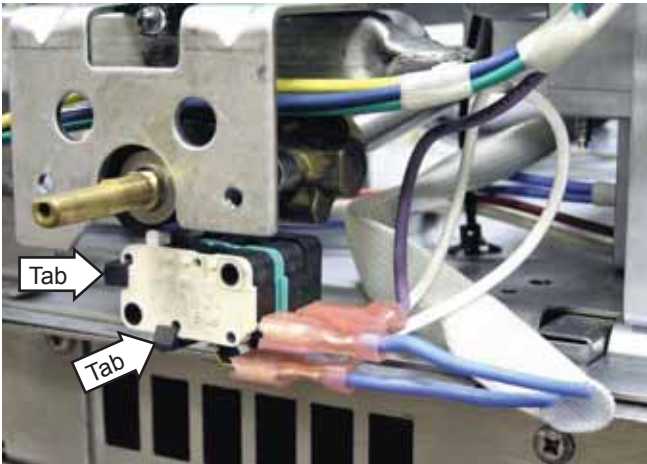

### To remove the grill control:

1. Remove the grill control switches.
2. Remove the grill assembly. (See **Grill Assembly**.)
3. Remove the 5/8-in. nut from the grill control gas outlet tube.

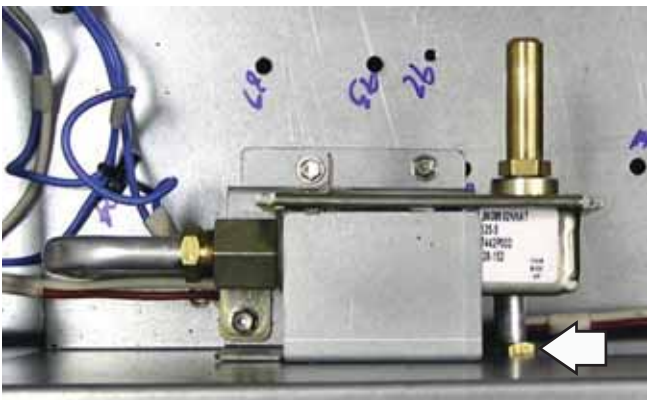

4. Using a ratchet wrench, remove the 1/4-in. hex-head screw that attaches the control to the manifold.

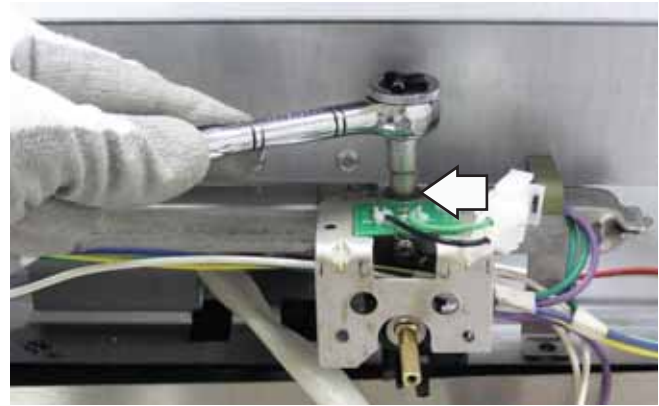

5. Separate the control from the gas outlet tube and manifold.

**Caution:** Ensure the control seal and the screw seal are in place BEFORE installing the control.

**Note:** Switch mounting bracket is a part of the valve assembly.

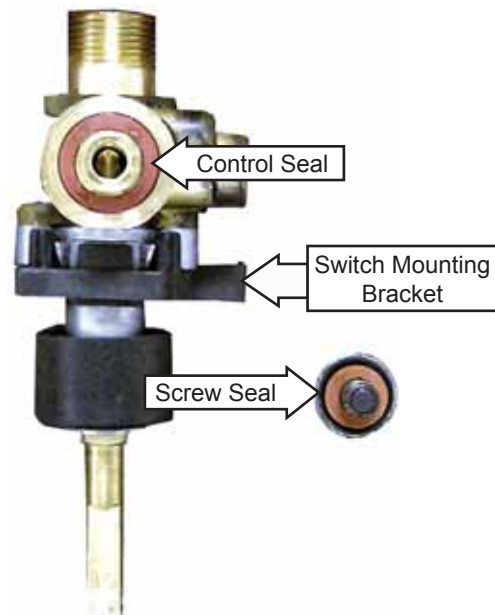

## Griddle Assembly

**Note:** The following describes the procedure to remove the griddle assembly.

### To remove the griddle assembly:

1. Remove griddle flue cover and grease trough.
2. Remove the (inner) clamping screws.



**Note:** It's recommended to remove the griddle completely when servicing the burner assembly. The griddle control has a capillary that is positioned securely to the underside of the griddle by a retainer that is attached with 2 Phillips-head screws.

3. Push the griddle toward the back of the range to release tabs from slots on the front of the range.

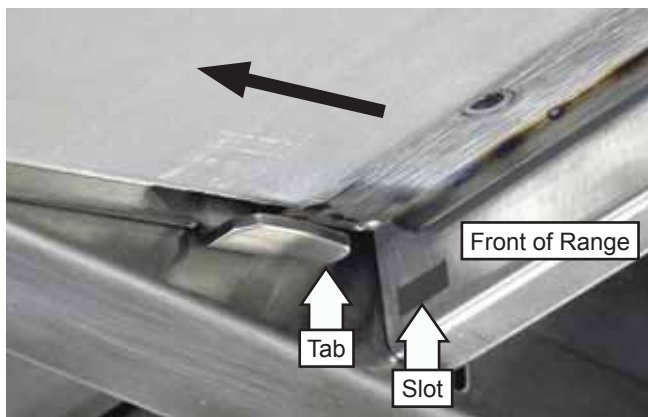

**Caution:** The griddle is heavy. Use care when lifting and rotating the griddle to prevent damage to the capillary.

4. Lift and rotate the griddle and remove the 2 Phillips-head screws and the retainer from the bottom of the griddle.

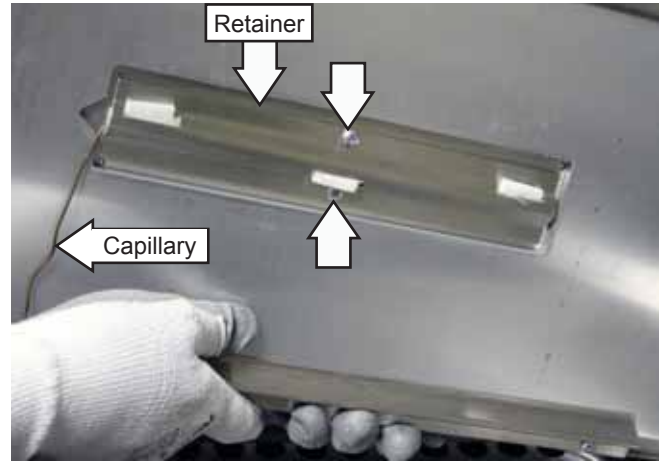

**Note:** When installing the retainer, ensure the capillary is in direct contact with the bottom of the griddle.

5. Remove the two 1/4-in. hex-head screws from the back of the grill burner.



**Note:** In the following step, ensure that the spring clip is captured and retained inside the griddle burner box.

6. Squeeze the ends of the spring clip and retract the clip from the harness access opening on the right side of the griddle burner box.
7. Lift the burner and pull the igniter wiring and harness connector through the opening.
8. Disconnect the igniter wire harness connector and remove the two 1/4-in. hex-head igniter screws.

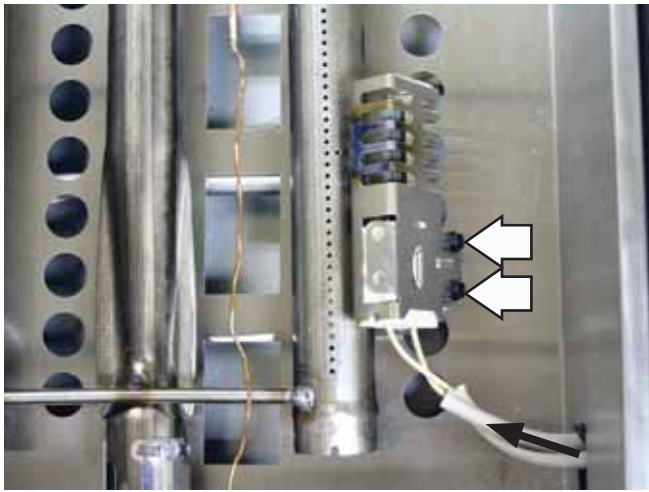

**Griddle Burner Removed**



9. Remove the grease trough.
10. Remove the 4 Phillips-head screws that attach the rear trim.
11. Place the control panel in the service position. (See **Control Panel**.)
12. Remove the 2 Phillips-head screws and the center trim, if applicable.

13. Remove the 2 Phillips-head screws from the front and the 2 Phillips-head screws from the rear of the griddle burner box.

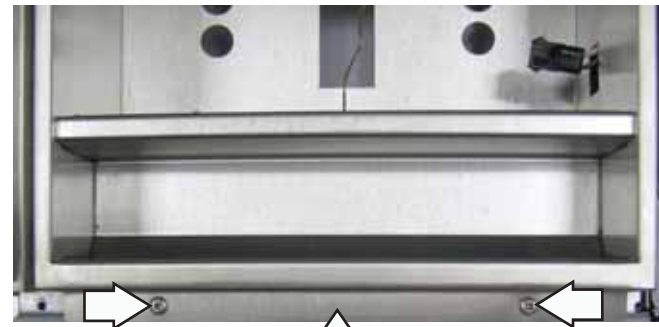

Front of Griddle Burner Box

Rear of Griddle Burner Box



15. Lift the burner box while carefully guiding the igniter wire harness connector and control capillary through their openings.



## Griddle Burner Igniter

The griddle burner igniter is attached to the right side of the griddle burner with two 1/4-in. hex-head screws. It is necessary to remove the griddle burner (See **Griddle Assembly**.), to access the screws and the igniter wire harness. The griddle igniter has a resistance value of 45 to 400  $\Omega$  at room temperature.

## Griddle Safety Valve

**Note:** The following describes the procedure to remove the griddle safety valve. The griddle safety valve has a resistance value of 1  $\Omega$  or less.

### To remove the griddle safety valve:

1. Place the control panel in the service position. (See **Control Panel**.)
3. Disconnect the 2 wires from the valve.
4. Remove the heat barrier.
5. Remove the 9/16-in. nut from the valve.

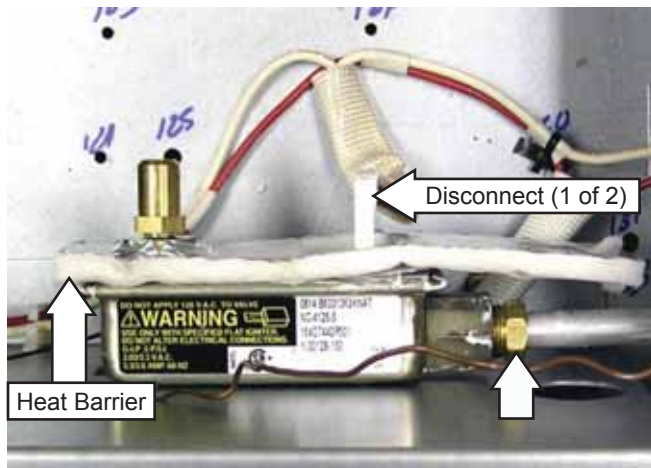

6. Remove the two 5/16-in. hex-head nuts that attach the valve to the chassis, then separate the valve from the chassis and gas tube.

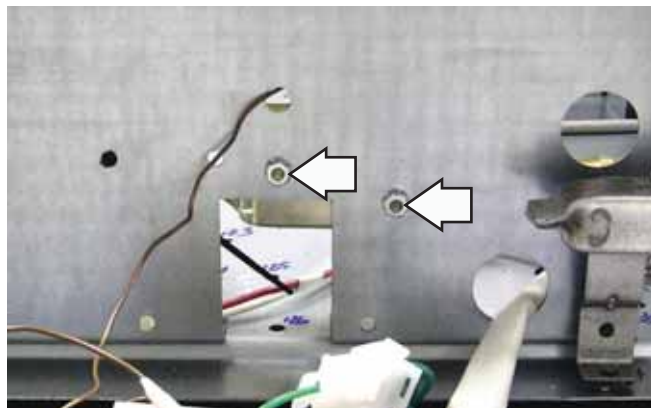

## Griddle Control

The control utilizes a capillary that senses griddle temperature and a switch that operates the LED indicator light. When the griddle knob is turned to the ON position, the control closes contacts that start the ignition process. The LED switch contacts also close and activate the LED indicator light. The LED switch can be replaced separately.

On rangetops, the griddle control is attached to a bracket that is held in place inside the front panel.

On ranges, the griddle control is attached to a manifold bracket.

### To remove the griddle control:

1. Remove the griddle, then remove the capillary retainer. (See **Griddle Assembly**.)

**Note:** On range models, it's a tight fit between the manifold bracket and the front frame of the range.

2. Remove the 2 Phillips-head screws and the griddle control from the control bracket (rangetops), or manifold bracket (ranges).

3. Place the cardboard insulator aside.

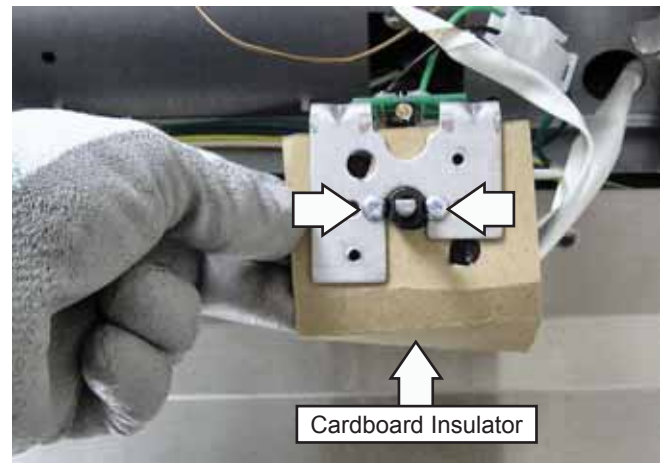

4. Slide the LED switch and switch plate off the control shaft.

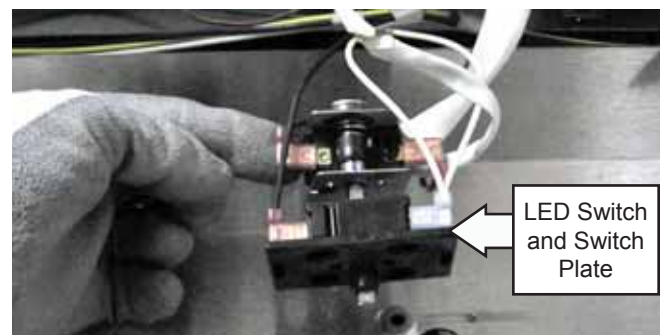

(Continued next page)

5. Slide the switch off the switch plate.

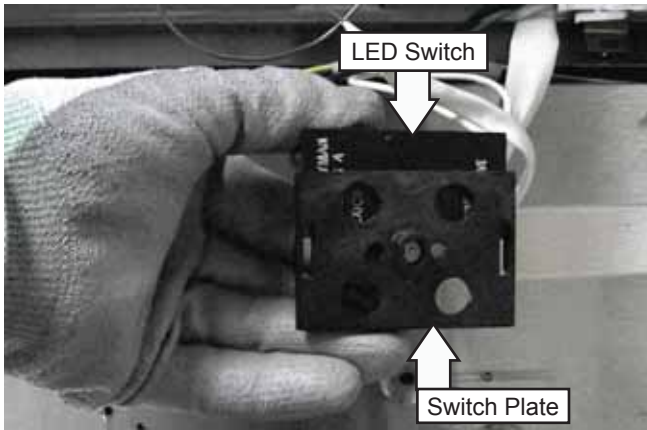

6. Remove wires from the LED switch.

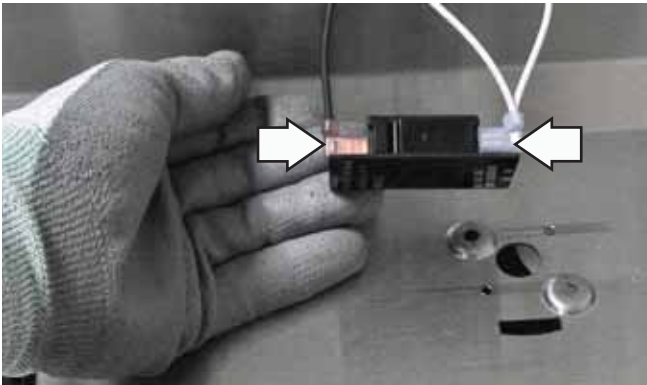

7. Remove wires from the control.

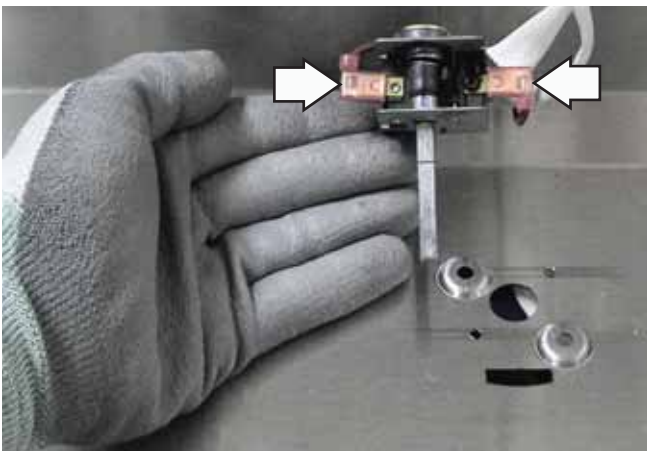

8. Slide the capillary out of the griddle burner box.

## Grill and Griddle Ignition Systems

The grill and griddle burners are ignited by a glow-bar ignition system. The igniter is a *Norton* style rectangular glow-bar. The grill and griddle ignition circuits consist of the control, an igniter, a hi limit switch (griddle only), and a safety valve. These components are wired in series for each cooking function.

The most important points to know about the ignition system are:

- THE IGNITER RESISTANCE DECREASES AS THE IGNITER SURFACE TEMPERATURE INCREASES.
- THE SAFETY VALVE OPERATES BY CURRENT, NOT VOLTAGE.

From a cold start, the igniter needs 30 to 60 seconds, with a minimum of 116 volts applied, to reduce its electrical resistance enough to provide a minimum of 2.9 amps of current flow in the series circuit. This is the required current flow needed for the safety valve to open and supply gas to the burner.

The glow-bar should provide a steady current flow of 3.4 to 3.6 amps (3.03 / 3.3 VAC) in the circuit. At that point, the igniter temperature is 1800°F to 2500°F (982°C to 1371°C). The igniter will remain energized at all times during burner operation. If the igniter glows red but does not draw at least 2.9 amps, the fault is usually with the igniter, not the valve.

Always check the gas shut-off valve located next to the pressure regulator for a *Not On* condition.

## Glow-bar Igniter

**WARNING:** The range and rangetop use rectangular *Norton* glow-bar igniters. They are NOT INTERCHANGEABLE with cylindrical *Carborundum* glow-bar igniters. The two types of glow-bar igniters operate at different amperage and use different gas valves.

Check the glow-bar circuit with a clamp-on ammeter. If igniter glows red but circuit does not draw at least 2.9 amps, the fault is likely with the igniter, not the valve.

**Note:** If igniter glows, but ignition does not occur, be sure the gas shut-off valve on the pressure regulator is in the open position.

Slow ignition can be caused by one or more of the following conditions:

1. Blockage of primary air intake: Inlet slots under bullnose (near LED light locations) must be open.
2. Blockage of secondary air intake holes: Examine grill and griddle burner boxes (galvanized box surrounding burner) and inspect the secondary holes beneath the burner for signs of blockage.
3. Improper alignment of orifice hood and burner: Orifice must be pointing straight into burner venturi.
4. Improper air/gas adjustment.
5. Blockage of griddle burner gas exit holes. Internal restriction or partial restriction inside the grill burner assembly.
6. The igniter should draw approximately 3.4 to 3.6 amps when operating. To check, carefully use a clamp-on ammeter at one of the igniter leads.

Grill Igniter Circuit Test



## Surface Burner Base

**Note:** The following describes the procedure to remove a single burner base. The procedure to remove the remaining burner bases is identical.

### To remove the burner base:

1. Lift off the burner grates, cap, and burner head.

**Note:** Five T-15 Torx screws attach the surface burner: 3 coarse thread screws on the outside, and 2 fine thread screws on the inside.

2. Remove the three T-15 Torx screws that attach the burner base to the burner pan and the two T-15 Torx screws that attach the burner base to the burner.



**Caution:** When removing the wire from the igniter, make sure you do not damage the heat shrink insulation on the wire. If damaged, repair the wire insulation with fiberglass tape.

3. Lift each burner base, note the color of the igniter wire, then disconnect the igniter wire.

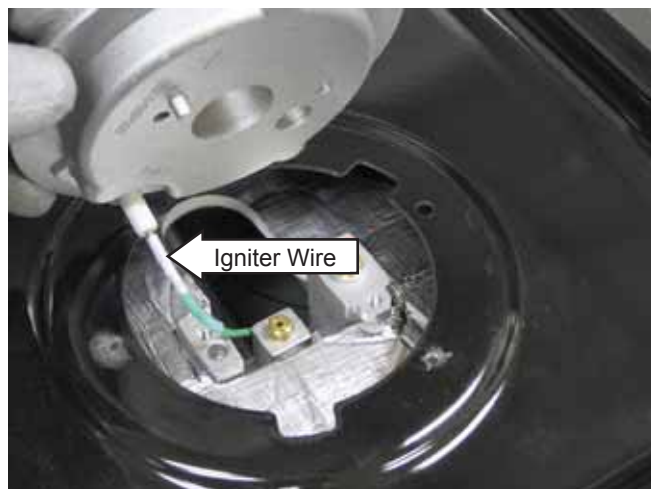

## Surface Burner Igniter

**Note:** The following describes the procedure to remove a single igniter. The procedure to remove the remaining igniters is identical.

### To remove the igniter:

1. Remove the burner base. (See **Surface Burner Base**.)
2. Use a small needle-nose pliers and remove the clip and spring from the igniter.

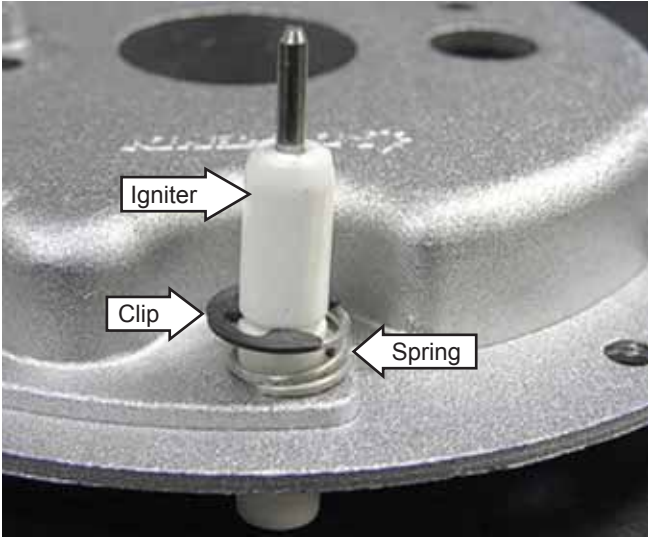

3. Pull out the igniter from the burner base.

## Surface Burner Pan

### Ranges

The following procedure describes the removal of the left-side surface burner pan on range models. The procedure to remove the right-side burner pan is similar.

**Note:** On the 36-in. six surface burner range, the pan is one piece and will require the removal of one side panel. (See **Side Access Panel**.) Then follow steps #1 through #4, #6 and #7 to remove the burner pan from under the remaining side panel.

### To remove the left-side surface burner pan:

1. Place the control panel in the service position. (See **Control Panel**.)
2. Lift off all the grates.
3. Remove the burner bases from the pan. (See **Surface Burner Base**.)
4. Remove the Phillips screws on the front of the oven vent, then pull the vent toward the front to release a tab at each end.



5. Remove the adjacent grill/griddle. (See **Grill Assembly** or **Griddle Assembly**.)
6. Remove the Phillips-head screws that attach the burner pan.

**Caution:** The burner pan has a lip that is captured under the left-side panel. To prevent scratching or chipping the pan, use extreme care when removing or installing the burner pan.

- Lift and tilt the right side of the burner pan, then carefully slide it out from under the left-side panel.



### Rangetops

The following procedure describes the removal of a surface burner pan on rangetop models.

**Note:** On the 36-in. six surface burner rangetop, the pan is one piece and will require removal of all six burner bases, side, and rear trims. Then, follow steps #1 and #5, to remove the pan.

#### To remove the surface burner pan:

- Place the control panel in the service position. (See **Control Panel**.)
- Lift off the adjacent grill/griddle grates.
- Remove the burner bases from the pan. (See **Surface Burner Base**.)
- Remove the Phillips-head screws, back trim, and side trim over the pan to be removed.
- Remove the Phillips-head screws that attach the burner pan.

**Caution:** The burner pan has a lip that is captured under the adjacent grill/griddle. To prevent scratching or chipping the pan, it may be helpful to loosen the adjacent grill/griddle burner box. (See **Grill Assembly** or **Griddle Assembly**.) Use extreme care when removing or installing the burner pan.

- Lift and tilt the side opposite the adjacent grill/griddle and slide it out from under the adjacent grill/griddle.

### Surface Burner

**Note:** The following describes the procedure to remove a single burner. The procedure to remove the remaining burners is identical.

#### To remove the burner:

- Remove the burner base. (See **Surface Burner Base**.)
- Remove the surface burner pan. (See **Surface Burner Pan**.)
- Remove the heat barrier by lifting it out of the burner box.

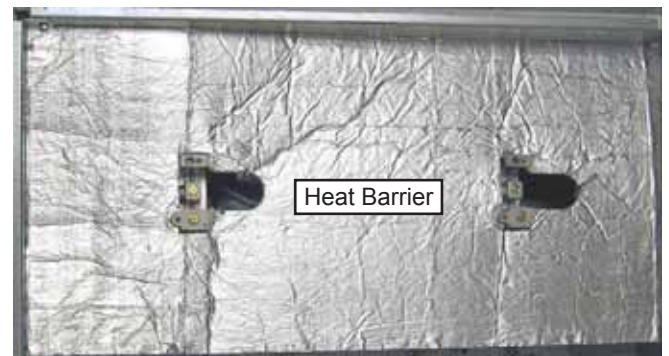

Heat barrier as viewed from side

- Remove the 9/16-in. nut and separate the main gas tube from the burner.
- Remove the 7/16-in. nut and separate the simmer gas tube from the burner.
- Remove the two 1/4-in. hex-head screws that attach the burner to the burner bracket.

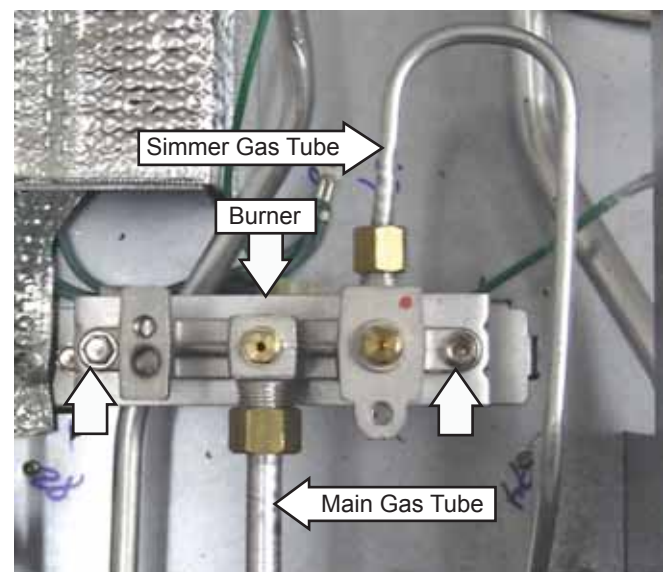

## Surface Burner Valve and Switch

Each surface burner valve utilizes a switch. When a burner knob is turned to the ON position, the valve switch closes and activates the spark module and the LED light. Each surface burner valve switch is installed on the front of the burner valve body. The switches are all wired to a single harness and are replaced as one assembly. It is necessary to remove the valve to access the switch.

**Note:** The following describes the procedure to remove a single burner valve and switch. The procedure to remove the remaining valves and switches is identical.

### To remove the surface burner valve and switch:

1. Remove the burner pan located over the valve and switch to be replaced. (See **Surface Burner Pan**.)
2. Remove the heat barrier by lifting it out of the burner box.
3. Remove the 7/16-in. nut and the 9/16-in. nut from the valve.

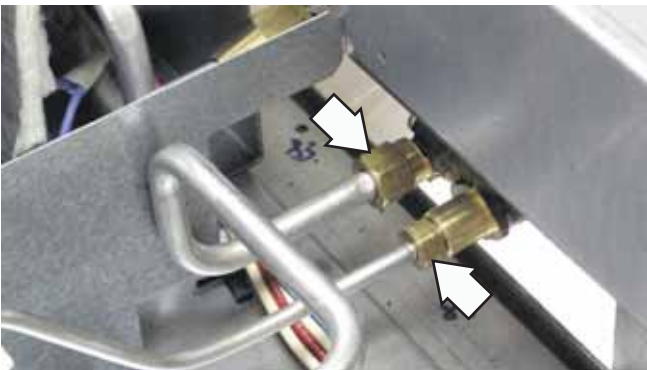

4. Remove the Phillips-head screw and the indicator light assembly from the valve bracket. (See **Indicator Light Assembly**.)

5. Slide down and remove the wiring retainer clip from the frame.
6. Using a ratchet wrench, remove the 1/4-in. hex-head screw that attaches the valve to the manifold.

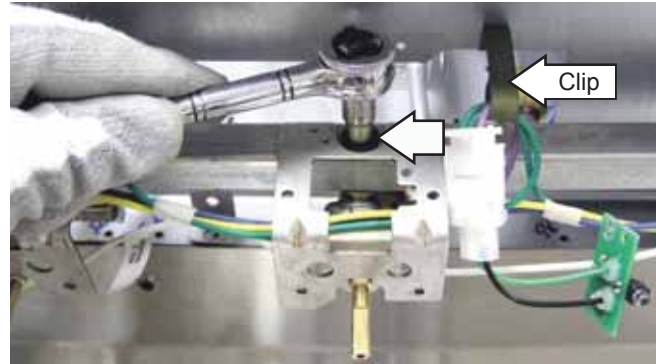

7. Maneuver the valve below the bracket and slide the valve switch from the valve stem.

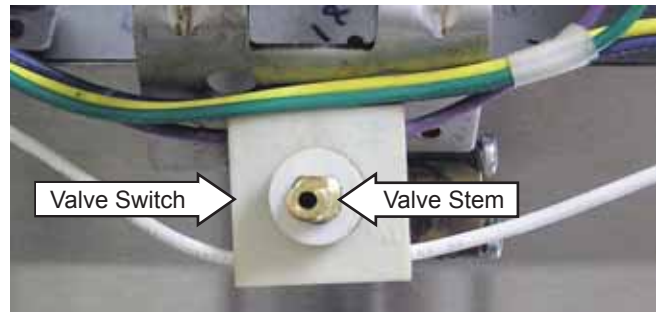

**Caution:** Ensure the valve seal and the screw seal are in place BEFORE installing the valve.

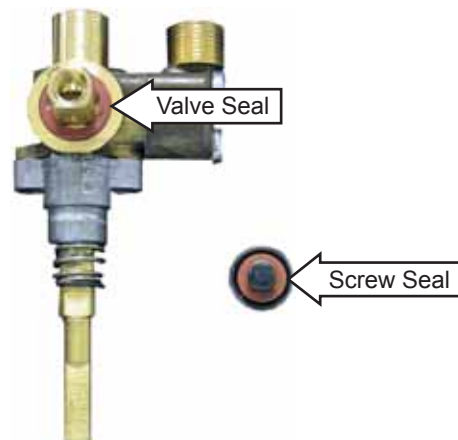

**Note:** The bottom of each switch is molded to conform to the front of the valve for a locked-in fit. For proper igniter operation, each switch must be locked-in to the top of the valve. When installing the switch, align each switch to the valve stem and body. Push the switch down firmly until an audible "snap" is detected.

## Spark Module

The spark module is located under the left-side surface burner pan.

### To remove the spark module:

1. Remove the left-side surface burner pan. (See *Surface Burner Pan*.)
2. Remove the three 1/4-in. hex-head screws that attach the module cover to the burner box.

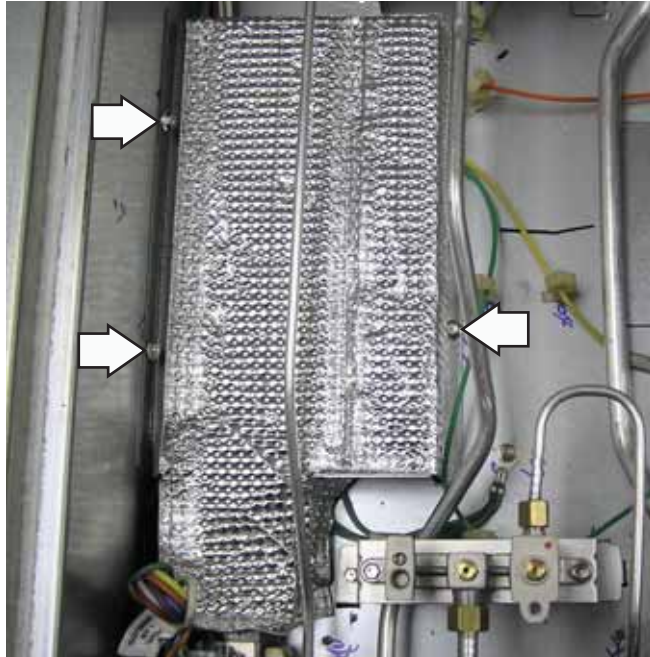

3. Remove the two 1/4-in. hex-head screws that attach the left rear burner to the burner bracket.
4. Lift the left rear burner and maneuver the module cover out from the burner box.



5. Remove the 2 Phillips-head screws that attach the module to the burner box.
6. Remove the Phillips-head screw that secures the module wire harness.
7. Mark and disconnect the igniter wires and disconnect the wire harness from the spark module.



## Transformer

The transformer is located under the left-side surface burner pan. The transformer windings have an approximate resistance value between:

Brown to brown (120 VAC primary) - 33  $\Omega$

Brown to red (240 VAC secondary) - 188  $\Omega$

### To remove the transformer:

1. Remove the left-side surface burner pan. (See *Surface Burner Pan.*)
2. Lift and peel back the front of the heat barrier to expose the transformer's front mounting screw.
3. Remove the two 1/4-in. hex-head screws that attach the transformer to the burner box.
4. Disconnect the surface burner igniter switch wire harness.
5. Remove the top screw from the harness bracket.

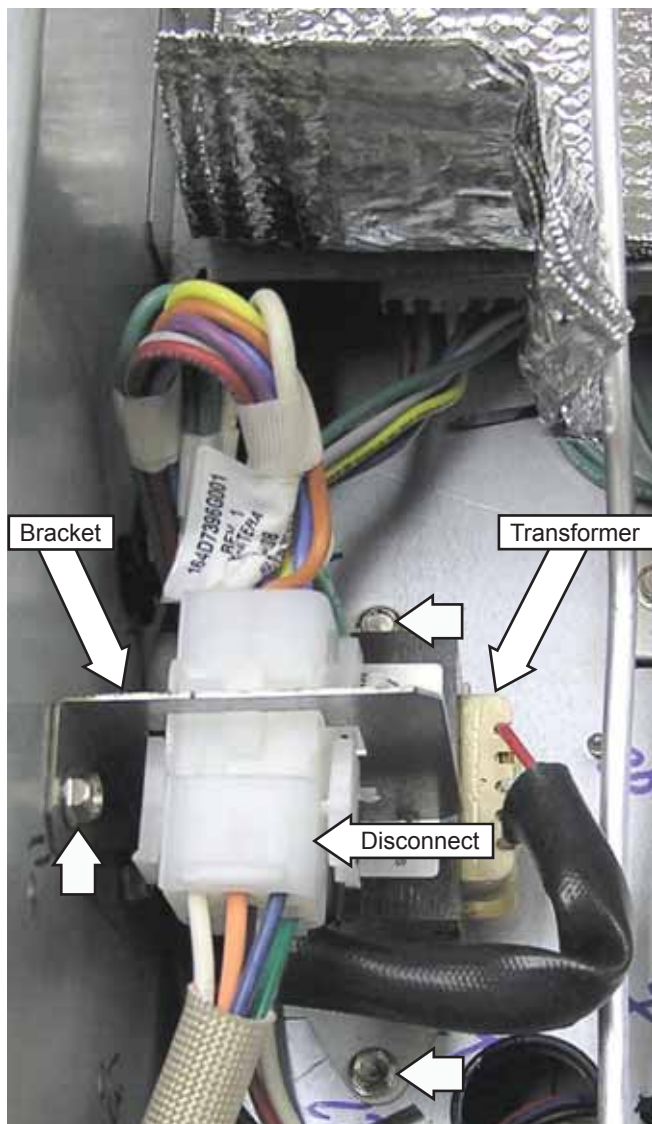

6. Maneuver the transformer to the right, then rotate the bracket forward to the horizontal position.
7. Disconnect the (secondary) wiring connector from the transformer harness that is retained in the harness bracket.
8. Using a flat blade screwdriver, push on the 2 tabs and remove the transformer (secondary) wire harness from the harness bracket.

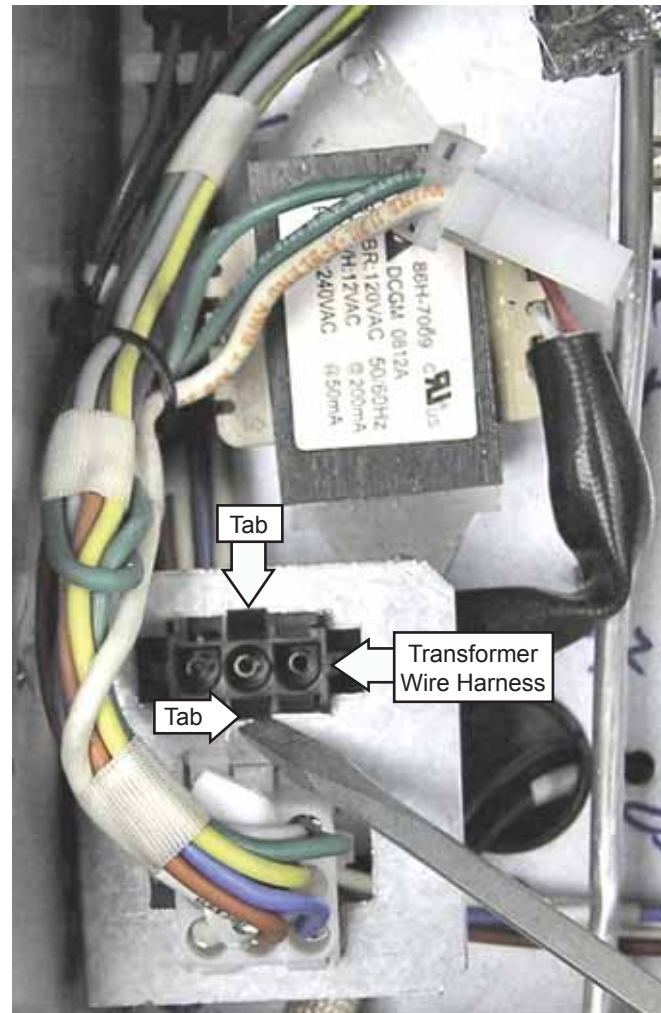

9. Disconnect the (primary) wire harness.

## LED Lights and Power Supply

The LED lights (task lighting) are located inside the control panel and are positioned to provide light over each bezel when activated by the task light switch.

### LEDs Activated



Each light is an assembly that consists of an LED and circuit board attached to a metal bracket with a Phillips-head screw. Each bracket is placed into a channel inside the top of the control panel. Loosening the bracket set screw allows the assembly to slide along the channel in order to be removed or positioned directly over each bezel. The circuit boards are wired in series to a light harness and are replaced as one unit. If one light assembly fails or a wiring connection is loose, all LEDs will be out.

**Note:** When replacing task lighting, make sure each light is centered over each bezel before installing the control panel.

On range models, the LED power supply is located above the surface burner manifold on the left side of the control area. It is accessible by placing the control panel in the service position. (See **Control Panel**.) The power supply is held in place with four 1/4-in. hex-head screws.

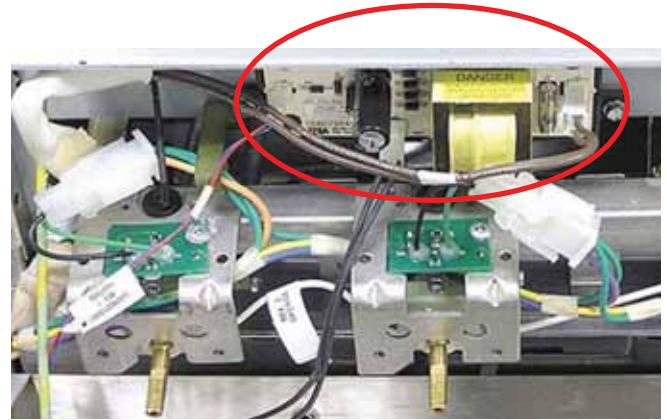

On rangetops, the LED power supply is located below the left-side surface burners. It is accessible by removing 2 Phillips-head screws that attach an access plate located on the bottom of the rangetop. The power supply is held in place with 4 Phillips-head screws.



### Power Supply Connections

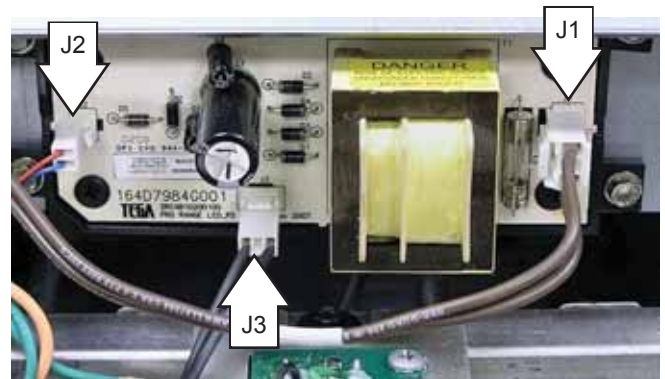

J1 - Input (120 VAC)

J2 - LED Output

J3 - Light Switch

## Task Light Switch

The task light switch is attached to the left side of the control panel with a 3/4-in. hex nut.

### To replace the task light switch:

1. Place the control panel in the service position. (See **Control Panel**.)
2. Disconnect the task light switch wire harness,
3. Remove the wire ties that attach the switch wire harness to the LED wire harness,
4. Remove the 3/4-in. hex nut from the switch.
5. Slip the nut over the harness connector, then remove the switch from the control panel.



## Indicator Light Assembly

Each surface unit (surface burner, grill, and griddle), utilizes an indicator light consisting of a circuit board with an attached Light Emitting Diode (LED). When a surface unit knob is turned to the ON position, the circuit board activates the LED and light is directed to the indicator lens of that surface unit's bezel.

Each light assembly is attached to a manifold valve bracket and connected to the valve switch wiring harness. Each light assembly can be replaced separately.

### To remove the indicator light assembly:

1. Place the control panel in the service position. (See **Control Panel**.)
2. Disconnect the LED wire harness.
3. Remove the Phillips-head screw that attaches the LED to the valve bracket.

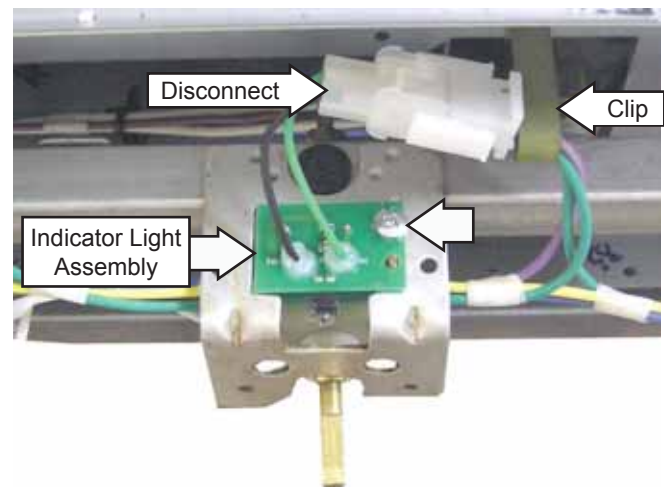

# Range Components

## Back Panel

The back panel is attached with seventeen 1/4-in. hex head screws. It is necessary to remove the range from the installation to access the screws. (See *Installation*.)

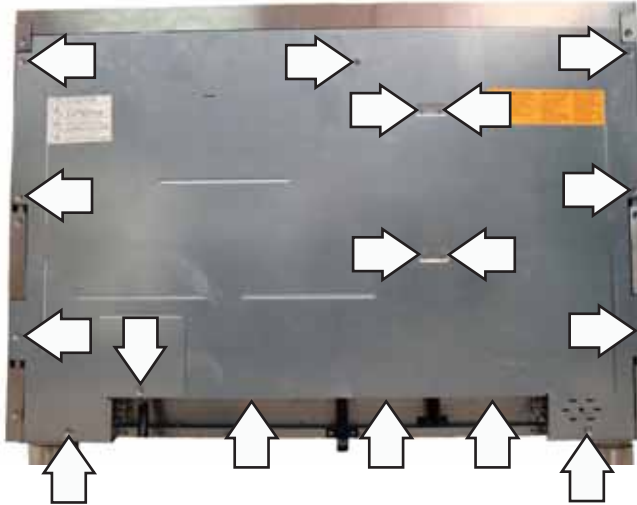

## Side Access Panel

To remove the side access panel:

1. Remove the range from the installation. (See *Installation*.)
2. Place the control panel in the service position. (See *Control Panel*.)
3. Remove the three 1/4-in. hex head screws that attach the side panel to the rear of the range.



4. Remove the 2 Phillips-head screws from the front of the side panel.

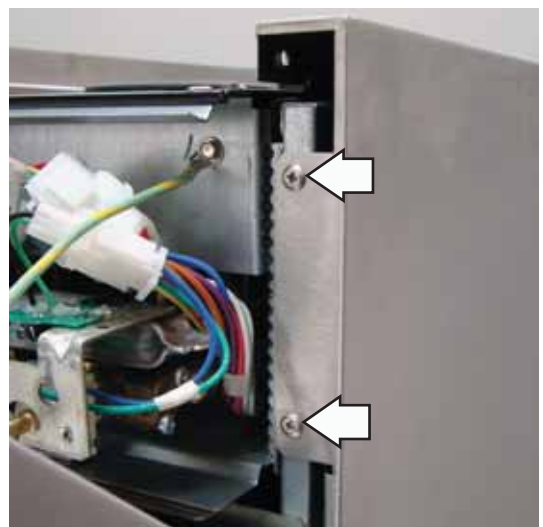

**Note:** The side panel is held to the front side of the range with 3 keyslots inside the panel that engage 3 plastic pins on the range.

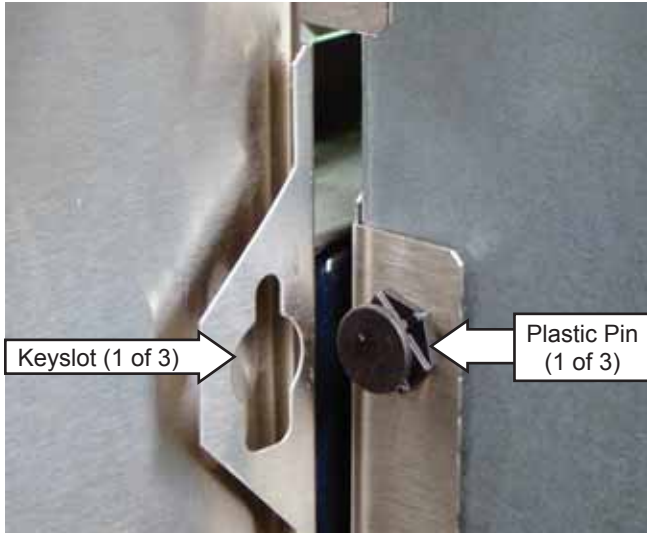

5. Move the rear of the side panel out approximately 2 inches from the range.
6. Lift the panel approximately 3/4 inch to disengage the panel from the 3 plastic pins.



View Inside Panel



Panel Moved Out

## Cooling Fan

The cooling fan is attached on the back of the oven with two 1/4-in. screws. The fan vents through the rear grill. On double oven models, each oven has its own independent fan that runs only when that oven is on. To replace the fan, it is necessary to remove the range from its installation and remove the back panel. (See **Installation, Back Panel.**)

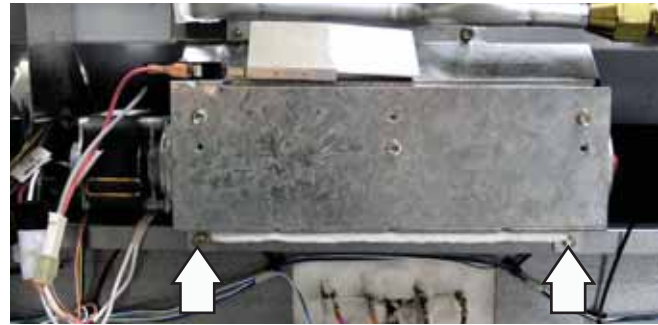

- In all cooking modes, the fan will not start to operate until the oven temperature reaches 200°F.
- It operates immediately at high speed in self-clean as soon as the door is locked.
- The fan will run for a maximum of 85 minutes after any cycle (cooking or cleaning) or until the sensor reaches 350°F, whichever comes first.
- In all cooking modes, the fan always runs in low speed. It will only run in high speed in the unlikely event the oven exceeds 600°F in a cooking mode.

Main oven fan characteristics:

- High speed = 3050 RPM +/- 100
- Resistance is 13  $\Omega$  measured through the black and white wires
- Low speed = 1525 RPM +/- 175
- Resistance is 20  $\Omega$  through the red and white wires

Companion oven fan characteristics:

- High speed - 2700 RPM +/- 150
- Resistance is 22  $\Omega$  measured through the black and white wires
- Low speed - 2225 RPM +/- 175
- Resistance is 26  $\Omega$  through the red and white wires

## Sail Switch

The sail switch is located at the top rear of the range, above the cooling fan. This switch monitors the presence of the airstream from the cooling fan. If the sail switch is open when the fan should be on, the logic board will disable power to all cooking elements. (See *Oven Sensor, Sail, and Door Switch Test*.)

The sail switch is attached to the cooling fan with two 3/16-in. hex-head screws. To access the sail switch from the front, remove the top back vent trim. To replace the switch, it is necessary to remove the range from its installation and remove the back panel. (See *Installation, Back Panel*.)

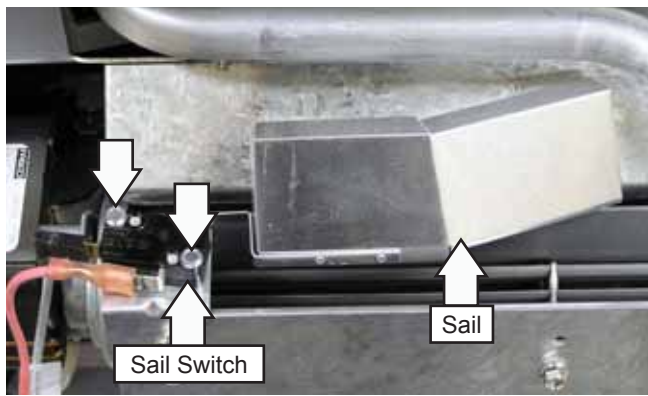

## Oven TCO

The oven TCO is located above the convection fan motor. The TCO is wired in series with the common side of all the elements, which are tied to the common side of the double line break relay. The TCO is used to protect against element runaway. If open, the elements will not work for any operation. The oven TCO opens at 284°F (140°C), and is non-resettable. When replacing an open TCO, determine the cause and make the necessary repairs.

The oven TCO is attached to the range with two 1/4-in. hex-head screws. To replace the oven TCO, it is necessary to remove the range from its installation and remove the back panel. (See *Installation, Back Panel*.)

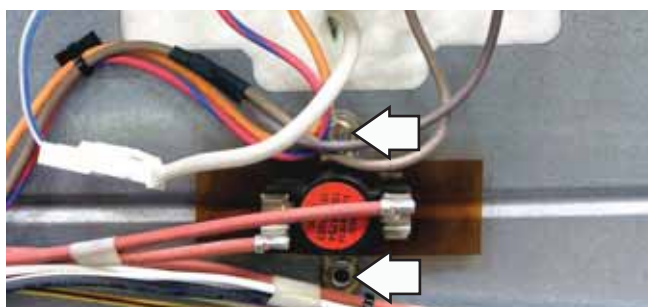

## Lock Assembly

The motorized door lock assembly is located above the oven. The assembly consists of a lock motor cam and switch assembly, lock hook, mounting plate, door switch, spring and plunger.

The lock motor is energized when the control is set for Clean and Clean Time selected. The K13 relay contact will close and complete the circuit that supplies the voltage to the lock motor.

Door locking or unlocking will close and complete the circuit that supplies voltage to the lock motor.

### Door Locking/Unlocking Strip Circuit

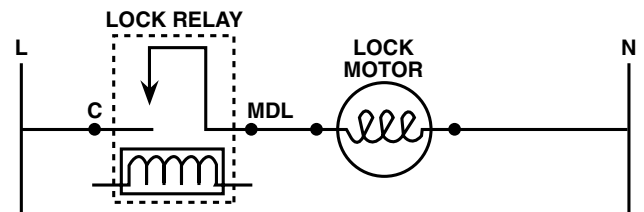

**Note:** To enable proper operation of the door lock, ensure that the door jamb switch contacts "common" to "normally closed" are closed (door closed position). This enables power to be delivered when the door lock closes.

The cam on the motor performs two functions:

1. Positions the lock hook in the door to prevent opening during the Clean operation.
2. Operates the lock switches, which tell the control if the door is unlocked or locked and ready for the Clean operation.

**Note:** When the door is either being locked or unlocked, both the lock and unlock switches will be in the open position. The LOCKED AND UNLOCKED diagrams are representative of a single oven. On double oven models, the diagrams apply to both models, except for the pin position. (See *Oven Sensor, Sail, and Door Switch Test* section for reference to double ovens).

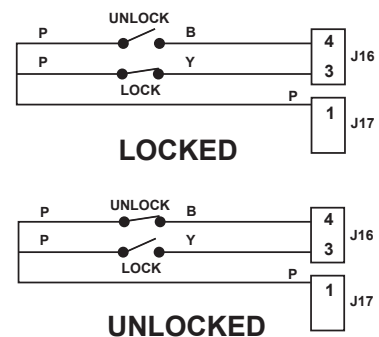

(Continued next page)

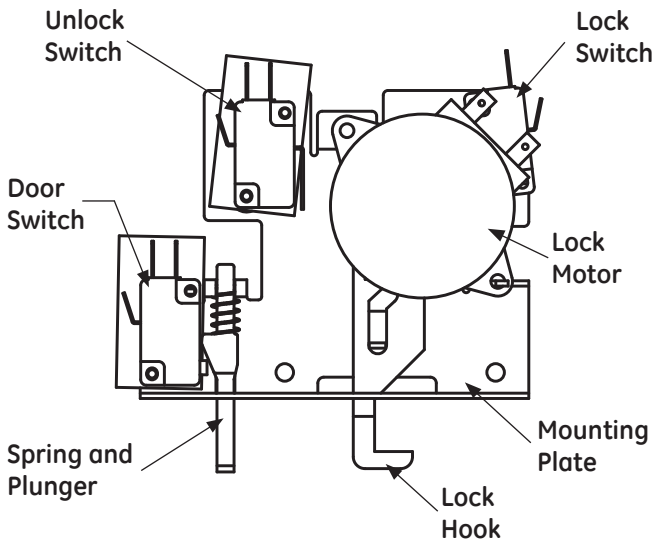

The lock assembly is attached to the oven frame by two 1/4-in. hex-head screws.

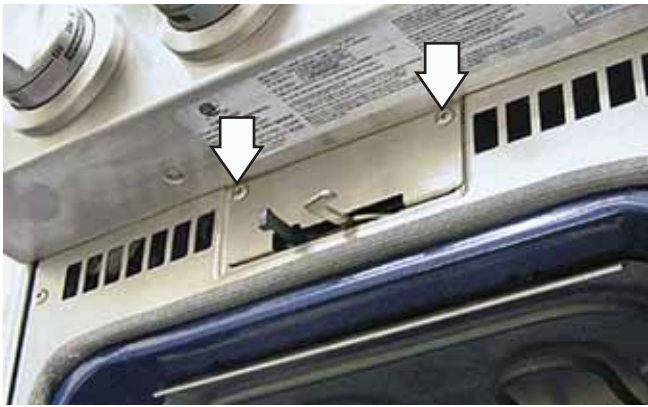

There is sufficient wiring to pull the door lock assembly out completely for service.



If the lock motor fails during a self-clean cycle, there is sufficient space between the oven door and control panel to remove the 2 Phillips-head screws holding the lock motor assembly. Carefully opening the door will pull the lock motor assembly out far enough to service.

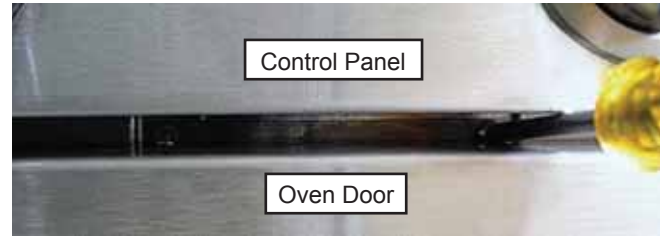

The lock motor has approximate resistance value of 1.9K  $\Omega$ .

**Caution:** It is possible to reconnect the switch wiring incorrectly to the lock assembly. When reconnecting the wiring, make sure it is properly connected to the lock assembly before turning the power back on.

### Lock Motor Circuit

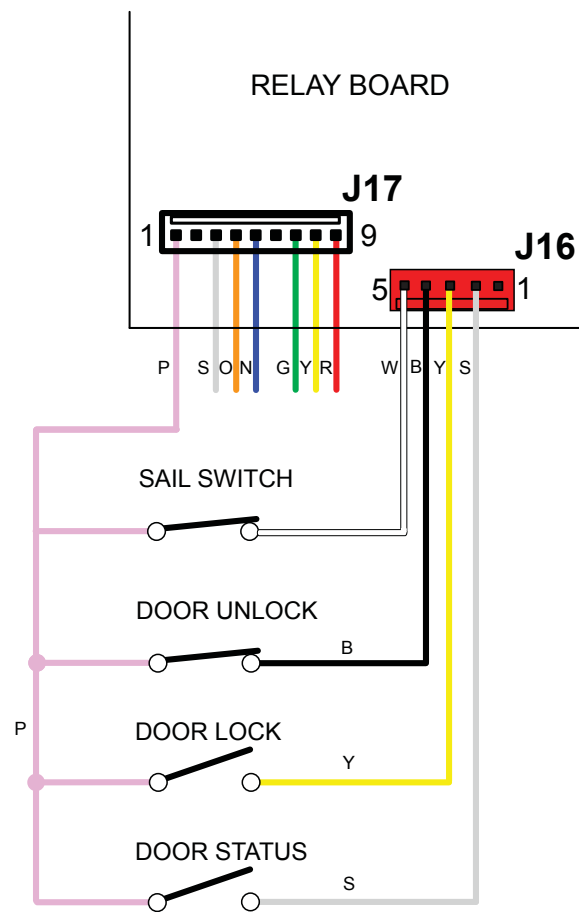

# Oven Components

## Door Assembly

The oven door can be separated into 2 assemblies. The outer assembly consists of the outer panel and a replaceable door handle. The inner assembly is made up of the inner panel, door gasket, 3 glass panels, insulation, heat barrier, and replaceable door hinge assemblies.

### To separate the door assemblies:

1. Remove the door.
2. Place the door assembly, gasket side up, on a protective surface.
3. Remove the 4 Phillips-head screws (3 on companion oven door) that attach the inner door assembly to the outer door assembly.



4. Remove the 2 Phillips-head screws located under the door gasket at the top of the door.



**Note:** The inner door assembly is heavier than the outer door assembly.

5. Separate the inner door assembly from the outer door assembly.

### To replace the outer door assembly:

1. Separate the door assemblies. (See **To separate the door assemblies**, this section.)
2. Remove the 3/8-in. hex-head screw that attaches the right-side of the door panel reflector to the right-side liner support.
3. Remove the remaining 3/8-in. hex-head screw that attaches the right side liner support and support spacer and remove the two 3/8-in. hex-head screws that attach the left-side liner support and spacer.
4. Lift and remove the reflector and liner supports from the outer panel.

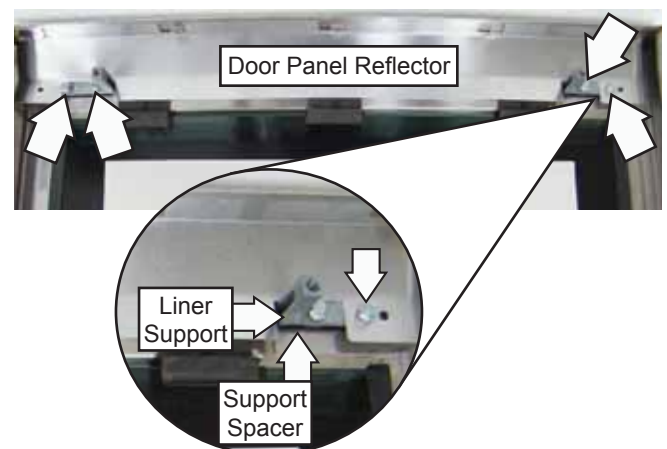

5. Remove the remaining four 3/8-in. hex-head screws (2 on each side) that attach the door handle assembly to the outer door panel.

**Note:** The tubular door handle is inserted and secured to each handle support with a 1/8-in. Allen screw located inside the support.

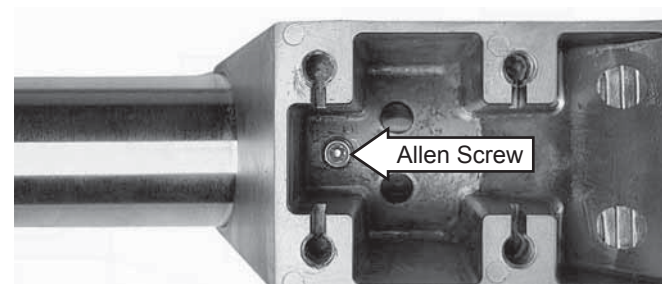

**Note:** For further details, see **Oven Doors (exploded view)**, this section.

(Continued next page)

## To replace the inner door assembly:

1. Remove the outer door assembly. (See **Door Assembly**.)
2. Remove the 4 T-20 Torx screws (2 on each side) that attach each door hinge to the inner door panel. Carefully turn the door over and remove both door hinges.



3. Remove the 2 Phillips-head screws, located on the oven side of the inner door assembly, that attach the top of the heat barrier to the inner door panel.
4. Remove the four 1/4-in. hex-head screws that attach the heat barrier to the inner door panel. Remove the barrier.

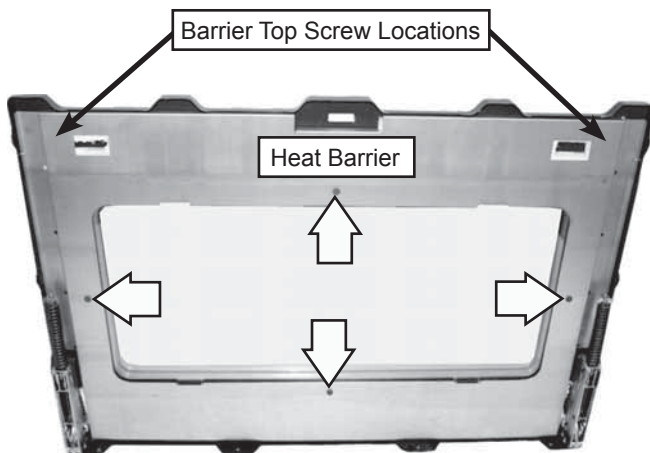

5. Remove the insulation and the 3 inner glass panels from the inner door.

**Note:** For further details, see **Oven Doors (exploded view)**, this section.

## Assembly Notes

When assembling, make sure the hinges are parallel to each other and perpendicular to the door liner. If not, the hinge may bind on the receiving channel of the door. If the new hinge is not in the cocked and locked position after installing, place the bottom of the door against a firm, protected surface and push the hinge arm down to the cocked position.

Pull the hinge lock back against the door liner surface to lock the hinge in this position.

Air enters the door assembly through large slots in the bottom and flows upward between the inner and outer assemblies, exhausting through slots in the top of the door. **DO NOT INSULATE THIS AIR CHANNEL.**

## Door Gasket

The gasket forms a complete seal around the front edge of the oven liner and the inner door panel. The door gasket is attached to the inner door panel by spring clips. When removing the gasket, pull the ends of the gasket out of the slots at the bottom of the door. Place a finger under the gasket beside each clip and pull straight up.

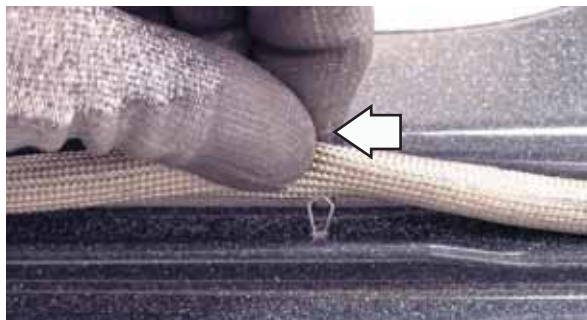

When installing the door gasket, it is helpful to fold the gasket in half and locate the center clip. Insert the clip at the top of the door and work your way around the door.

Make sure the gasket is tucked into the bottom slots of the inner door panel. Use a small screwdriver to tuck the loose ends of the gasket into the slots.

Oven Doors (exploded view)

Companion Oven Door

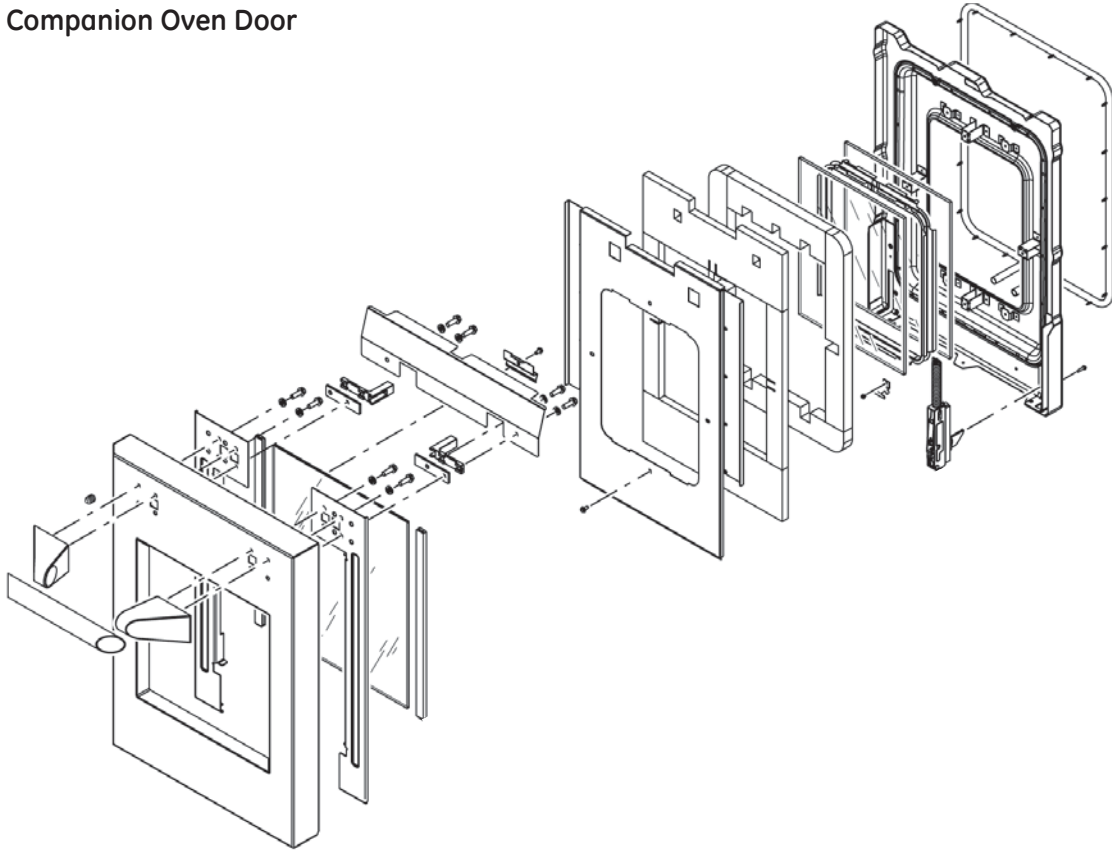

Main Oven Door

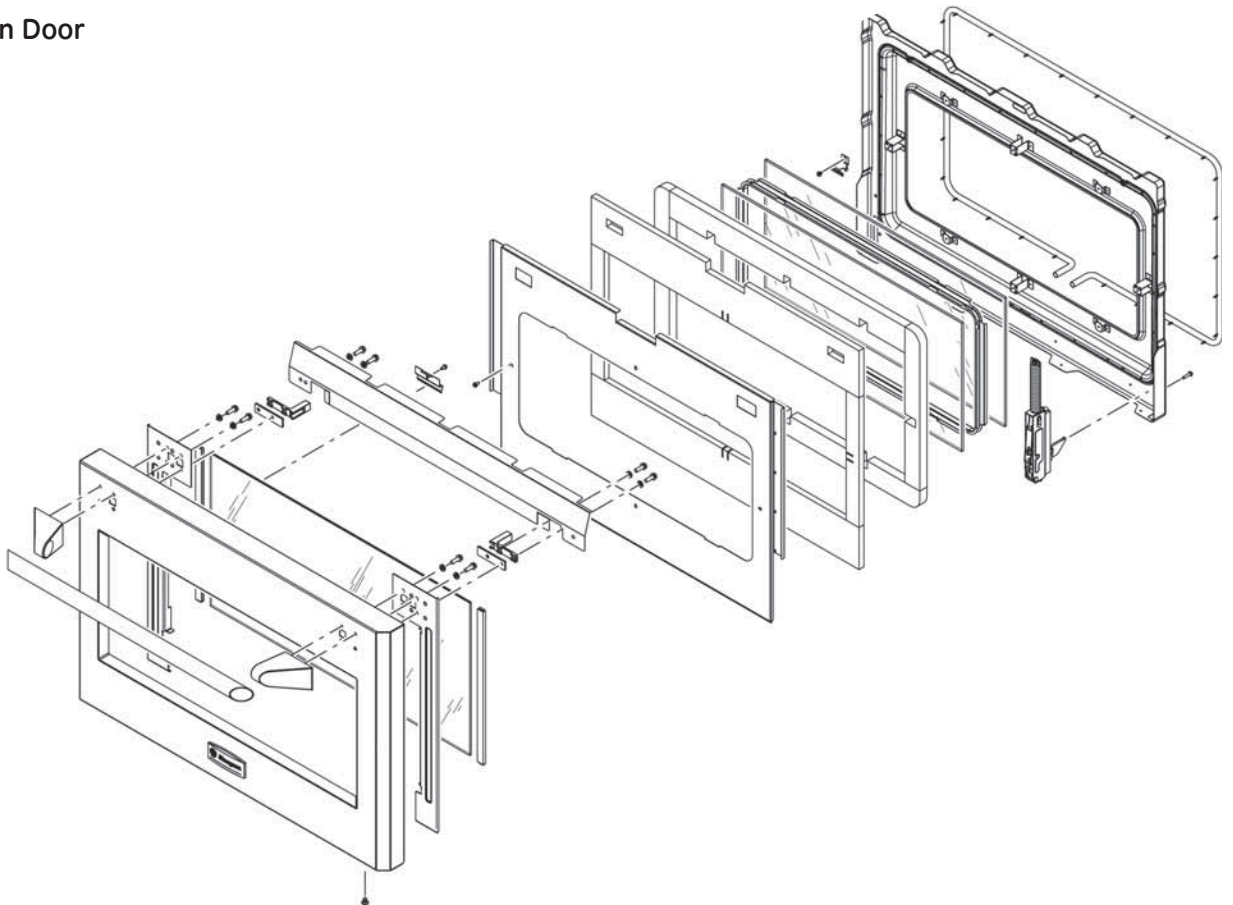

## Oven Racks

**WARNING:** To avoid possible burns, remove or install the racks before turning on the oven.

### To remove a rack:

1. Make sure the rack is pushed all the way into the oven.
2. Grasp the rack by both its upper front rail and its lower front rail and lift straight up to unlock the front rack locks from the rack supports.

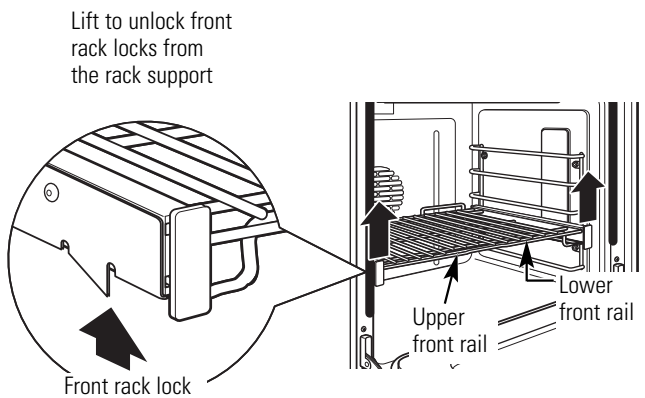

3. Firmly holding onto both the upper and lower front rack rails, pull the rack forward and remove it from the oven.

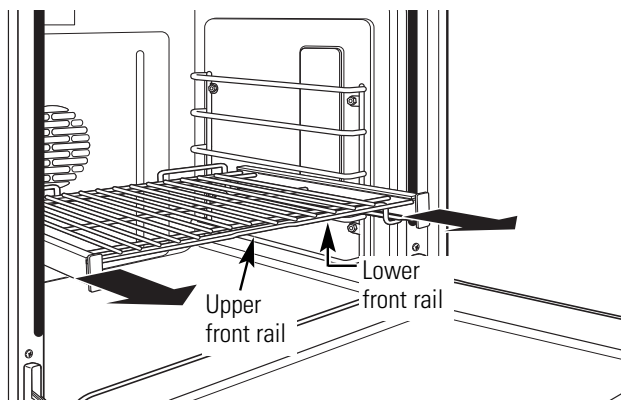

### To install a rack:

1. Place the rear rack locks over and onto the rack supports. (Five rack positions are available, including the top position.)

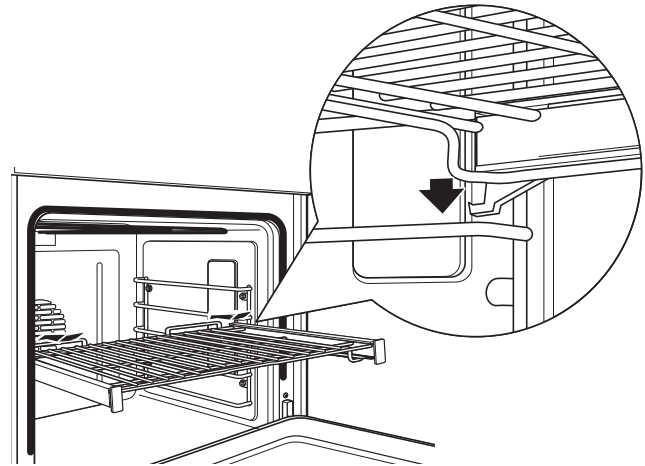

2. Slide the rack all the way in until the rear rack locks are secure on the rear rack supports, and press the front rack locks onto the front rack supports.

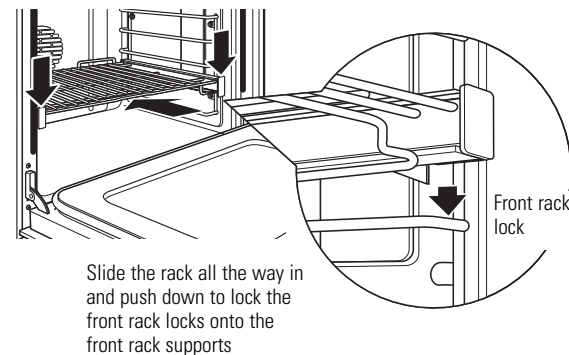

3. Pull the rack all the way out to check that it is properly engaged.

### Care and Cleaning

#### Note:

- The racks may remain in the oven during the self-cleaning cycle without being damaged.
- Periodically, after several self-clean cycles, the oven racks may need to be lubricated using the graphite lubrication shipped with the wall oven. To order additional graphite lubrication, call our National Parts Center at 800.626.2002 and reference WB02T10303.

### Lubricating an oven rack:

1. Remove rack from the oven.

*(Continued next page)*

2. Fully extend the rack on a table or countertop. Newspaper may be placed underneath the rack for easy clean up.

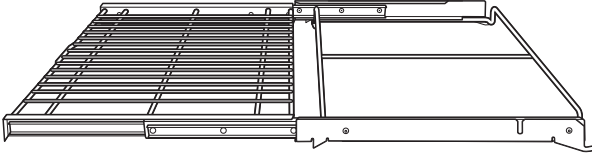

3. If there is debris in the slide tracks, wipe it away, using a paper towel.

**Note:** Any graphite lubricant wiped away must be replaced.

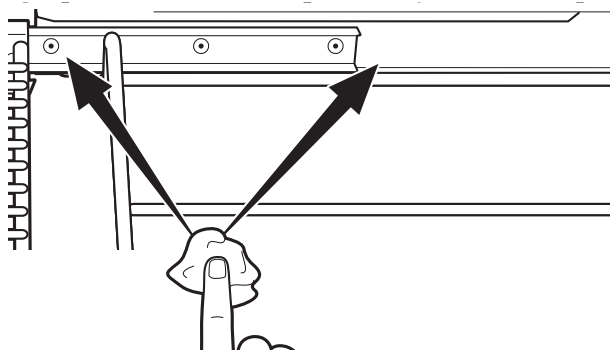

4. Shake the graphite lubricant before opening it. Starting with left slide mechanism of the rack, place 4 small drops of lubricant on the 2 bottom tracks of the slide close to the bearing carriers.

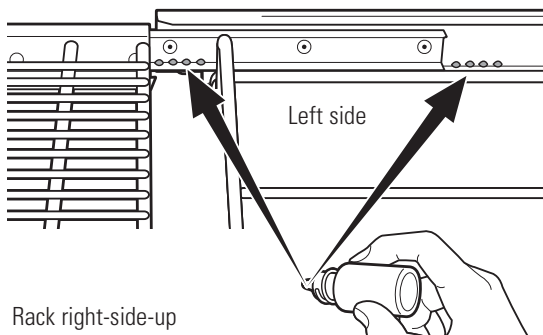

5. Repeat for the right slide mechanism of the rack.

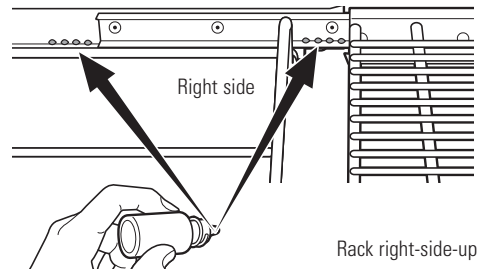

6. Open and close the rack several times to distribute the lubricant.
7. Replace the cap on the lubricant and shake it again. Turn the rack over and repeat steps 3, 4, 5 and 6.
8. Close the rack. Turn rack right-side-up and install in the oven.
9. Repeat above steps for each rack.

**Note:** Do not use a cooking spray or other lubricant spray on the slides.

## Oven Temperature Sensor

The oven temperature sensor has a resistance of:

- 1091  $\Omega$  at room temperature
- 1654  $\Omega$  at 350°F
- 2634  $\Omega$  at 865°F (Clean temperature)

The oven temperature sensor has a resistance change rate of 2  $\Omega$  per °F.

**Note:** For test locations see *Oven Sensor, Sail, and Door Switch Test*.

### To remove the oven temperature sensor:

1. Disconnect power.
2. Remove oven racks. (See *Oven Racks*.)
3. Remove the two 1/4-in. hex-head screws that attach the sensor to the broiler element bracket.

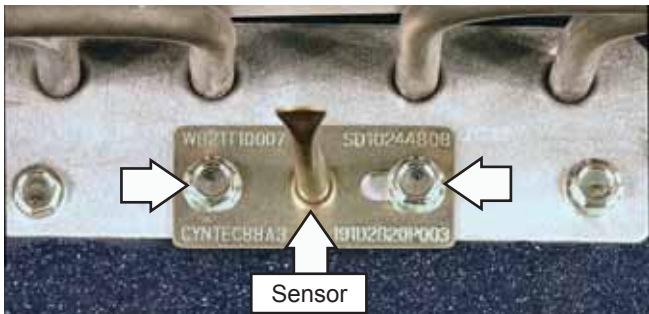

4. Carefully pull the sensor and sensor wiring harness from the oven liner.
5. Disconnect the sensor wiring harness.

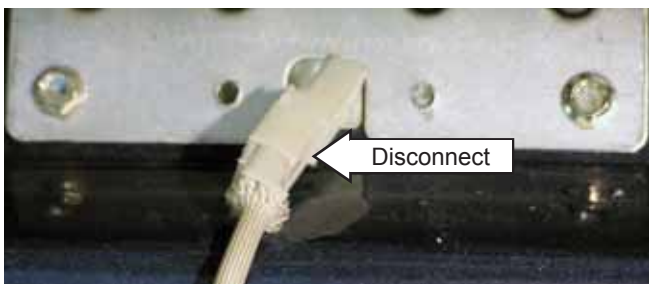

**Note:** When reinstalling the sensor, use a small flat-blade screwdriver to push and guide the sensor wire harness into the oven liner.



## Broil Elements

The broil cycle is closed door only. The display will scroll "CLOSE door" if the door is left open in the broil cycle. If the door is not closed within 60 seconds, the broil cycle will shut off and display "End". The cycle must be reset to start broil again.

- The broil element is composed of an inner and an outer element. It is replaced as one unit.
- The broil element will not work if the temperature probe is plugged in.
- The main oven inside element is rated at 3000 watts, has an approximate resistance value of 18.78  $\Omega$ , and draws approximately 12.1 amps.
- The main oven outside element is rated at 1000 watts, has an approximate resistance value of 55.2  $\Omega$ , and draws approximately 3.7 amps.
- The companion oven inside element is rated at 2100 watts, has an approximate resistance value of 26.5  $\Omega$ , and draws approximately 8.4 amps.
- The companion oven outside element is rated at 1400 watts, has an approximate resistance value of 39.7  $\Omega$ , and draws approximately 5.4 amps.
- Broil element wiring is very tight, but the broil element can be tested and replaced from inside the oven cavity
- The broil element is located on the back wall of the oven and can be removed from inside the oven cavity.

### To remove the broil element:

1. Remove oven racks. (See *Oven Racks*.)
2. Remove the two 1/4-in. hex-head screws that attach the sensor to the broiler element bracket. (See *Oven Temperature Sensor*.)
3. Carefully pull out the sensor approximately 2-in. from the broiler element bracket.

(Continued next page)

- Remove the two 1/4-in. hex-head screws that attach the element bracket to the oven liner.



- Remove the 1/4-in. hex-head screws that hold the broiler element reflector to the oven cavity.

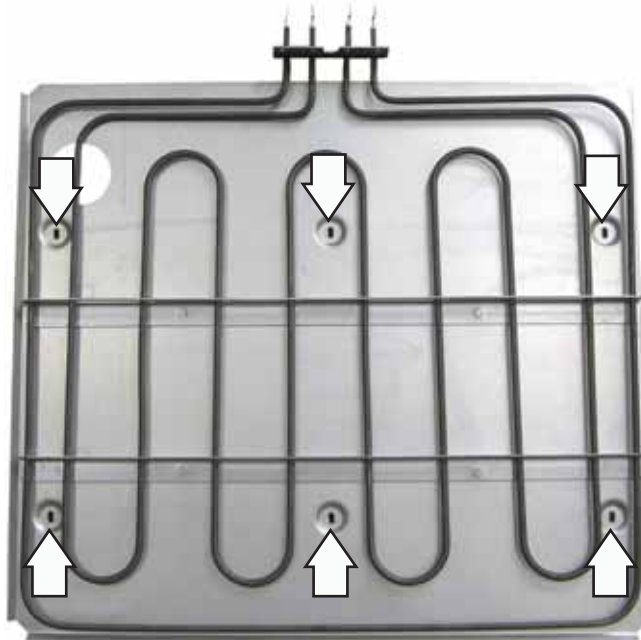

**Main Oven Reflector Screw Locations**

- Carefully pull, then lower the broiler element towards the front of the oven until the element terminals are accessible.

**IMPORTANT:** The lower wattage outer element utilizes 3/16-in. terminal connections. The higher wattage inner element utilizes 1/4-in. terminal connections.

- Disconnect the wires from the broiler element.

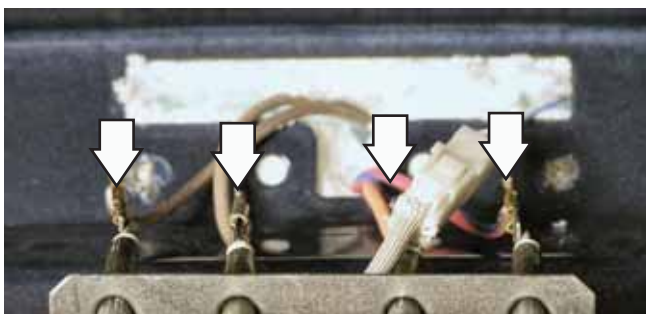

## Convection Bake Element

- The convection bake element is composed of an inner and an outer element. It is replaced as one unit.
- The main oven inside element is rated at 900 watts, has an approximate resistance value of 62  $\Omega$ , and draws approximately 3.4 amps.
- The main oven outside element is rated at 1600 watts, has an approximate resistance value of 35  $\Omega$ , and draws approximately 6.3 amps.
- The companion oven inside element is rated at 800 watts, has an approximate resistance value of 69.25  $\Omega$ , and draws approximately 3.0 amps.
- The companion oven outside element is rated at 1425 watts, has an approximate resistance value of 39  $\Omega$ , and draws approximately 5.5 amps.
- The convection element can be tested and replaced from inside the oven cavity.
- The convection bake element is located on the back wall of the oven and can be removed from inside the oven cavity.

### To remove the convection bake element:

- Remove oven racks. (See *Oven Racks*.)

**Note:** To remove the convection cover in the companion oven, it is necessary to remove one of the rack supports. (See *Oven Light Assemblies*.)

- Remove the four 1/4-in. hex-head screws that hold the convection cover to the back wall of the oven cavity.

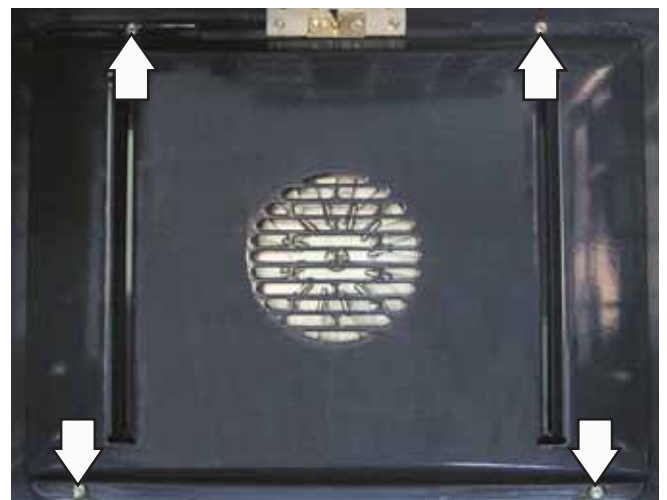

(Continued next page)

- Remove the three 1/4-in. hex-head screws that hold the convection bake element to the back wall of the oven cavity.



**Caution:** To avoid scratching the oven floor, cover the floor with protective surface.

- Carefully pull the convection bake element towards the front of the oven until the element terminals are accessible.

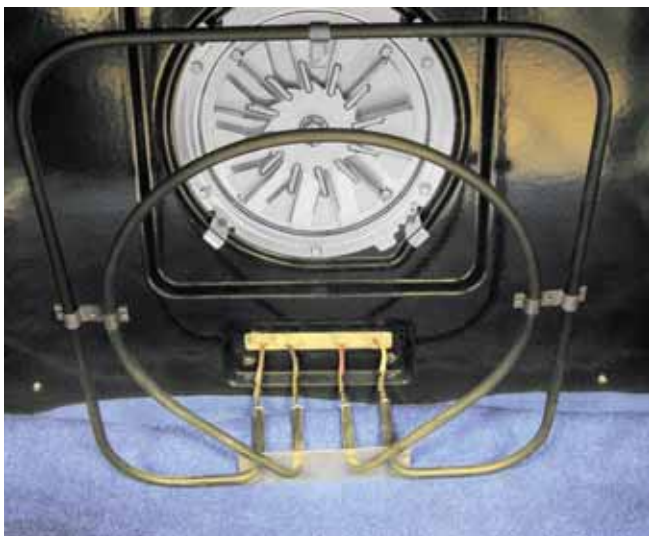

**IMPORTANT:** The lower wattage inner element utilizes  $\frac{3}{16}$ -in. terminal connections. The higher wattage outer element utilizes 1/4-in. terminal connections.

- Disconnect the wires from the convection bake element.

## Convection Fan Assembly

The convection fan assembly is located on the back wall of the oven cavity and consists of the fan guard, blade, insulation, and motor. The fan motor utilizes a capacitor that can be accessed from the recess below the oven. (See **Component Locator Views**.) The convection fan assembly can be removed from inside the oven.

The convection fan operates during the following modes:

- **Preheat**
- **Convection Bake**
- **Convection Broil**
- **Convection Roast**

**Preheat** - the fan will start after a 10-second delay, and then will always rotate CCW (no direction changes on any model).

**Convection bake and convection roast** - fan directional cycles will not start until preheat has completed.

**Convection broil** - fan starts immediately without preheat.

**Convection roast** - fan will always rotate CCW (no direction changes on any model).

### Convection fan cycling during convection bake:

- 12" cavity: cycles 15 seconds CW / 22 seconds off / 25 seconds CCW / 22 seconds off.
- 30" cavity: cycles 35 seconds CW / 20 seconds off / 25 seconds CCW / 20 seconds off.
- 36" cavity: cycles 17 seconds CW / 10 seconds off / 25 seconds CCW / 10 seconds off.

### Convection fan cycling during convection broil:

- 12" cavity: cycles 38 seconds CW / 10 seconds off / 30 seconds CCW / 10 seconds off.
- 30" cavity: constant CCW.
- 36" cavity: constant CCW.

**Note:** The convection fan shuts off when the door is opened.

(Continued next page)

## Convection Air flow

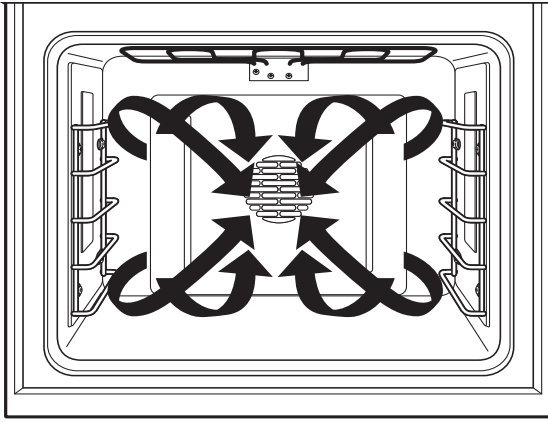

The convection fan motor has approximate resistance values between the following wires:

White to yellow/blue (CW) - 92  $\Omega$

White to yellow/red (CCW) - 77  $\Omega$

### To remove the convection fan and motor assembly:

1. Remove oven racks. (See *Oven Racks*.)

**Note:** To remove the convection cover in the companion oven, it is necessary to remove one of the rack supports. (See *Oven Light Assemblies*.)

2. Remove the four 1/4-in. hex-head screws that hold the convection cover to the back wall of the oven cavity.
3. Remove the outer six 1/4-in. hex-head screws that attach the fan assembly to the back wall of the oven cavity.

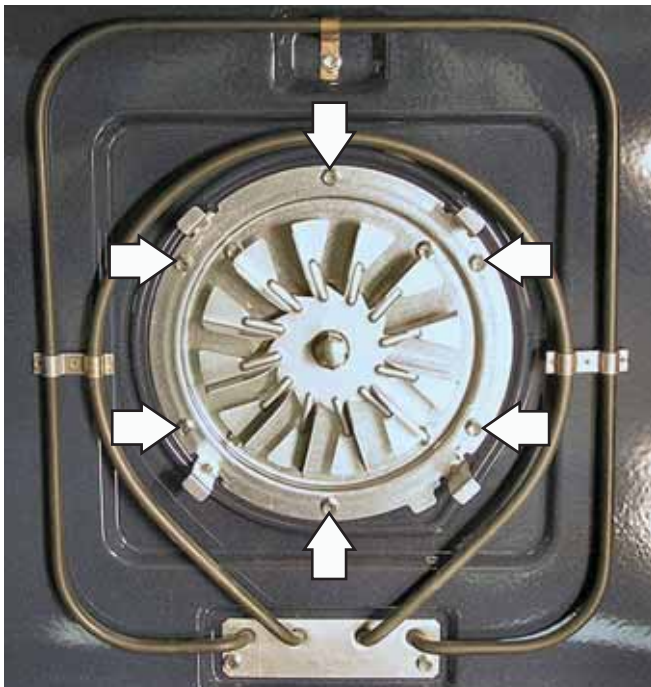

**Caution:** To avoid scratching the oven floor, cover the floor with protective surface.

4. Carefully pull the fan assembly into the oven cavity and disconnect the fan motor wire harness.

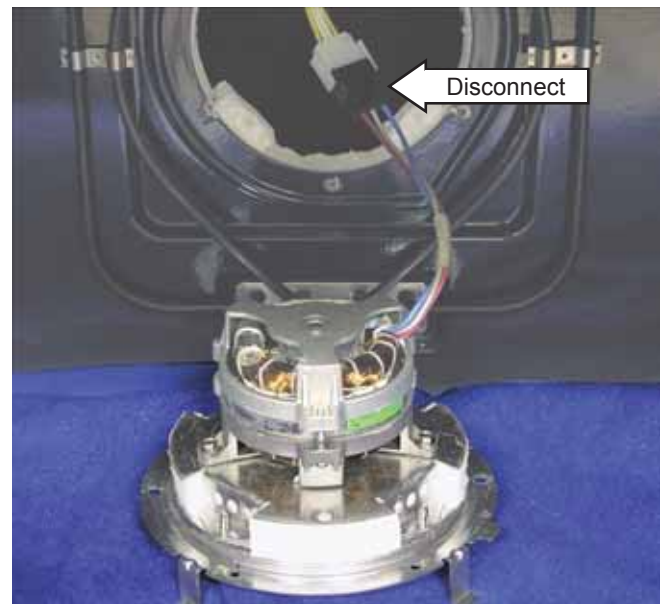

5. The fan blade is attached to the motor shaft with a left-hand thread 1/2-in. hex-nut. Turn the nut clockwise to remove.

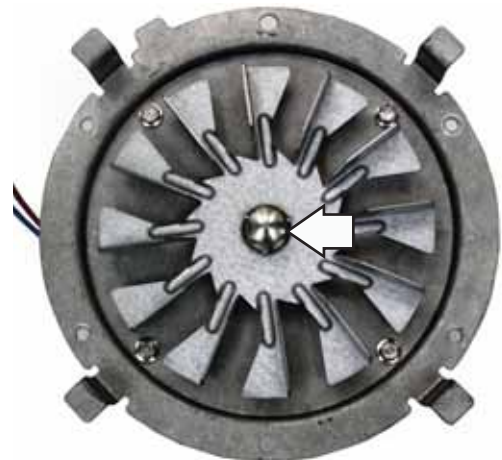

## Oven Control Logic Board

The oven control logic board consists of several boards and a frame. The logic board controls oven operation through user input and feedback from the oven sensor and switches. The oven control logic board is attached to the inside center of the control panel, and is only available as a complete assembly. It is necessary to lower the control panel to replace the oven control logic board.

### To remove the oven control logic board:

1. Remove the oven control knobs.
2. Place the control panel in the service position.  
(See *Control Panel*.)

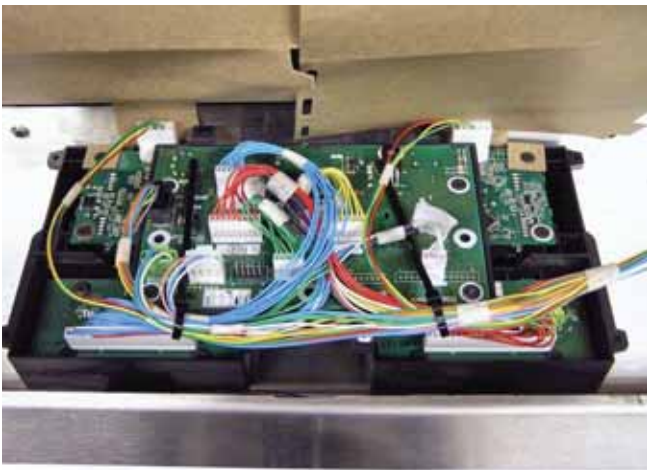

3. Remove the 3 Phillips-head screws (6 on double oven models), that attach the oven control logic board to the control panel, then carefully lift the assembly from the control panel.



Screw Locations for Double Oven Models

## Oven Relay Board

The oven relay board is located below the oven cavity and is accessed by removing a bottom panel and lowering the board to the floor.

### Note:

- The board will not have enough clearance to slide out if the front leveling legs are in their lowest position.
- There is sufficient wiring to pull the relay board out completely to the service position.
- The majority of the connections are color coded to match the wiring.
- Both the main and companion oven relay boards are accessed using the same method.

To access and place the oven relay board in the service position it is necessary to remove the three 1/4-in. hex-head screws at the front and pull the panel out from the tabs at the rear.

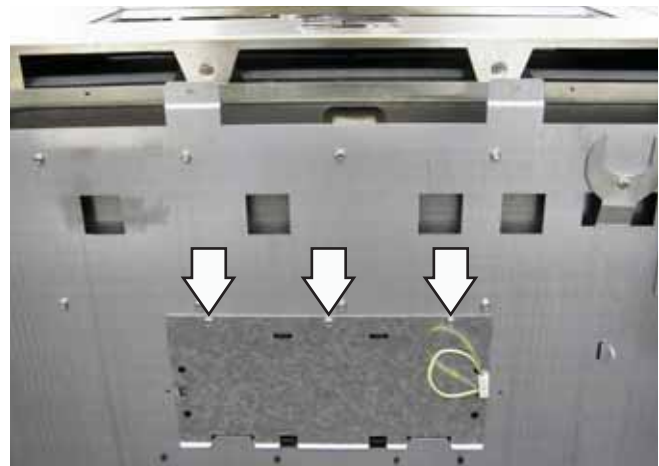

Bottom View of Range

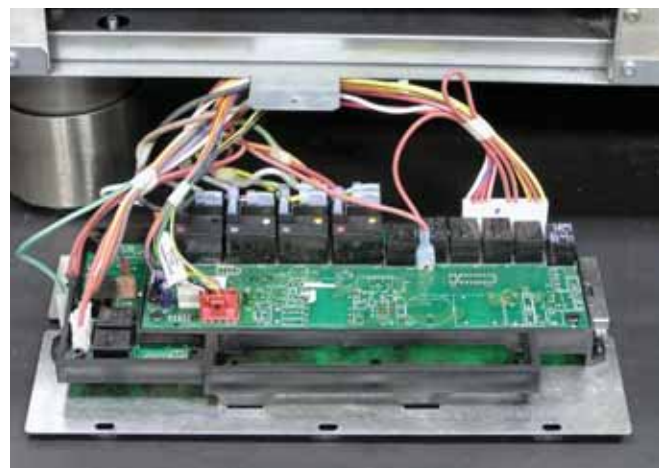

Service Position

## Bake Element

- Both main and companion ovens utilize true hidden bake elements.
- The bake element is composed of 2 elements and is replaced as one unit.
- The main oven bake element number 1 is rated at 1200 watts, has an approximate resistance value of 46.6  $\Omega$ , and draws approximately 4.6 amps.
- The main oven bake element number 2 is rated at 1000 watts, has an approximate resistance value of 55.9  $\Omega$ , and draws approximately 3.7 amps.
- The companion oven bake element number 1 is rated at 1000 watts, has an approximate resistance value of 55.9  $\Omega$ , and draws approximately 3.7 amps.
- The companion oven bake element number 2 is rated at 600 watts, has an approximate resistance value of 93.2  $\Omega$ , and draws approximately 2.3 amps.
- The bake element connector is located behind the access panel below the door.
- The bake element is located under the oven floor.

### To remove a bake element:

1. Remove the oven door. (See **Door Assembly**.)
2. Lower the relay board access panel to provide needed clearance. (See **Oven Relay Board**.)
3. If necessary, extend the right front leveling leg down to provide the needed clearance to lower the bake element shelf. (See **Installation**.)

4. Remove the lower access panel.

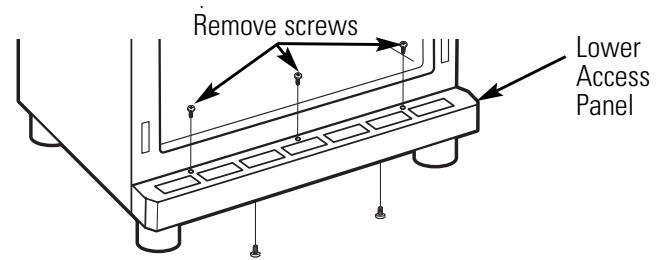

5. Disconnect the bake element wire harness.

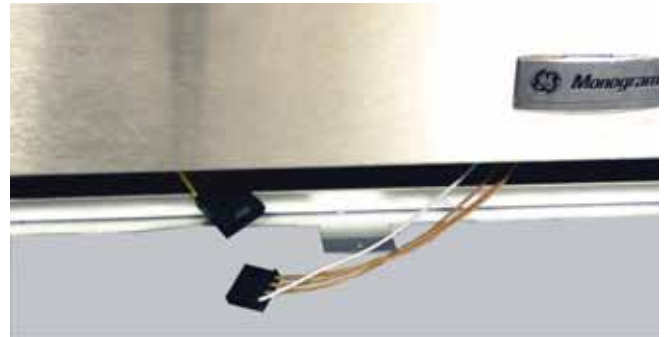

**Caution:** In the following step, the shelf is heavy and will drop down once the screws are removed.

### Note:

- The bake element shelf in the companion oven may not drop down if the leveling leg is retracted. Raise the front of the range to lower the leg and prevent interference.
  - If the hidden bake assembly does not lower far enough to access it, make sure the relay board and front legs are sufficiently out of the way to provide adequate clearance. **DO NOT TRY TO FORCE THE HIDDEN BAKE ELEMENT.**
6. Remove the two T-15 Torx screws to lower the bake element shelf. Use **CAUTION** as the shelf is heavy and may drop down once the screws are removed.

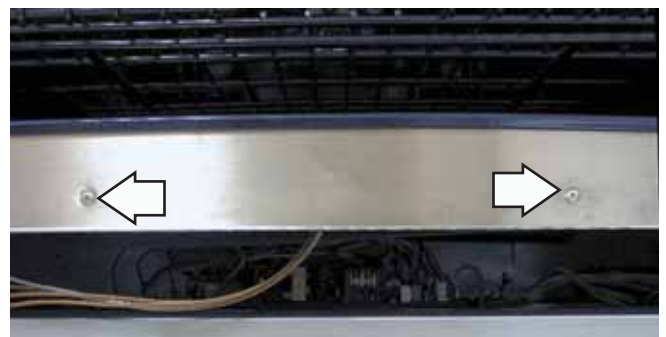

7. Remove the 1/4-in. hex-head screw on the left end of the cover plate.



8. Slide the cover plate to the left to disengage the tab, then remove the cover plate.

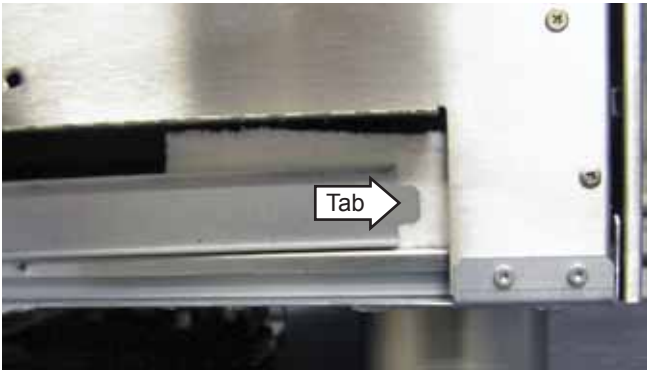

10. Carefully remove the front center insulation piece.

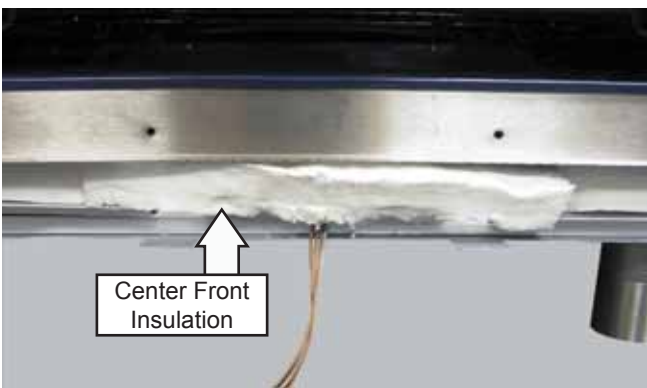

**Note:** Upon reassembly, ensure displaced insulation around oven and components is returned to its original position.

11. Note the position of the wiring harness through the opening in the bottom of the shelf and the surrounding gasket.

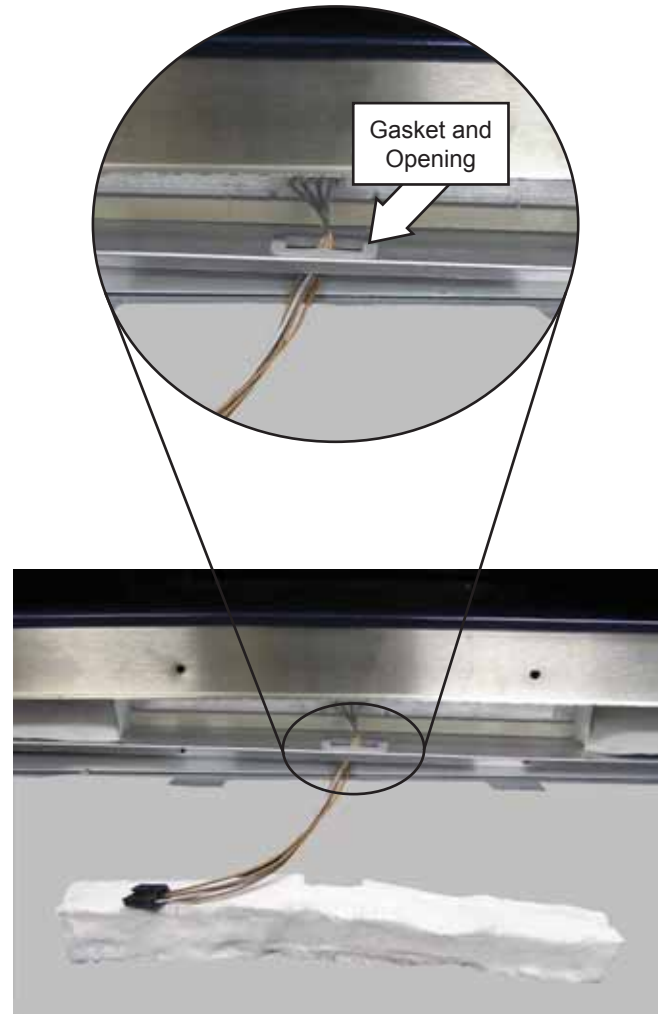

12. Slide the hidden bake element out from the range.

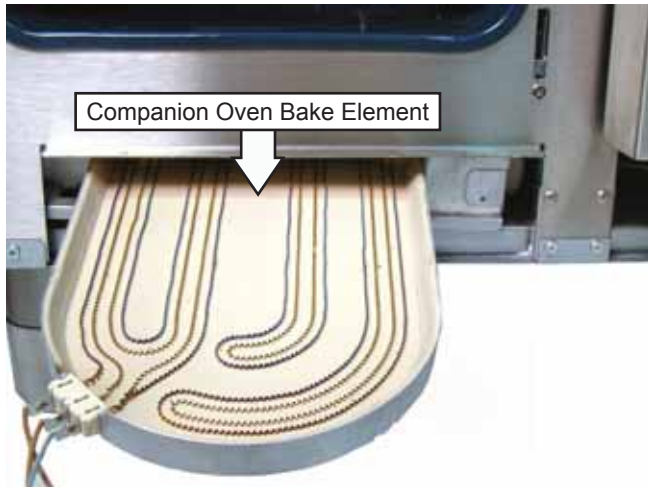
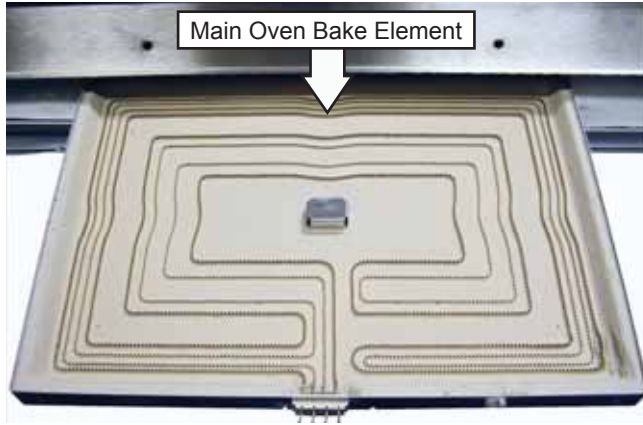

Main Oven Element Wire Identification	
Element Harness	Connection to Range Wire
Pin #1	Yellow - Bake1 Element
Pin #2	Red/Yellow - Bake 2 Element
Pin #3	Brown - Bake 2 Element
Pin #4	Brown - Bake1 Element

Companion Oven Element Wire Identification	
Element Harness	Connection to Range Wire
Pin #1	Brown - Bake 1 and 2 Element
Pin #2	Red - Bake 2 Element
Pin #3	Yellow - Bake 1 Element

## Meat Probe Receptacle and Harness

Each oven is equipped with a meat probe receptacle and harness. The probe outlet is located near the top right front corner of the oven cavity on 30- and 36-in models, and on the right side of the main oven and the left side of the companion oven on 48-in models. The meat probe outlet is connected to the logic board in the control compartment with the harness. The meat probe has a resistance value of 30K-50K  $\Omega$  at room temperature.

### To remove the meat probe receptacle:

1. Separate the light housing from the oven liner on the probe side of the oven cavity. (See *Oven Light Assemblies*.)
2. Remove the 3/8-in. hex-head nut that holds the meat probe outlet to the inside of the oven.
3. Pull the meat probe receptacle out of the oven liner.



4. Note the location of each wire, then disconnect the wires from the meat probe receptacle.



(Continued next page)

**To remove the meat probe receptacle harness:**

1. Remove the range from the installation.
2. Remove the back panel. (See *Back Panel*.)
3. Disconnect the meat probe outlet wire harness.

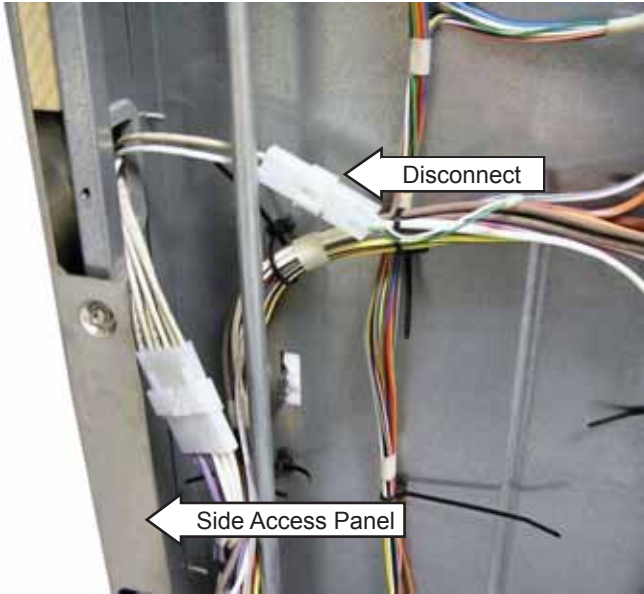

4. Tape a length of wire to the probe wire harness connector to act as a retrieval wire.

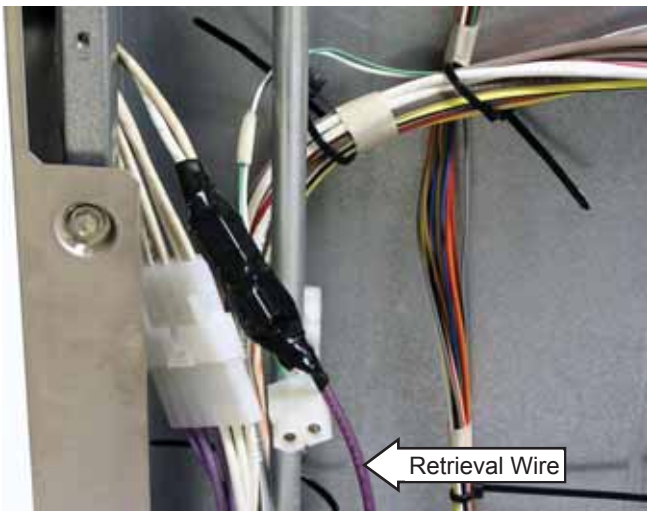

5. Remove the meat probe receptacle. (See *To remove the meat probe receptacle*, this section.)

6. Carefully pull the probe wire harness, and part of the retrieval wire through the light housing opening.



7. Untape the retrieval wire from the probe wire harness connector.

**Note:** Upon reassembly, ensure displaced insulation is returned to its original position.

## Oven Light Assemblies

Each main oven is equipped with two halogen light assemblies located on the side walls of the oven. The oven door switch monitors the position of the oven door and provides this information to the logic board. The logic board operates the light relay located on the relay board. The lights come on when the door is opened or when the oven is in a cooking cycle. The oven lights do not come on during self-cleaning or if the Sabbath Feature is set.

Each light assembly consists of a removable light cover with two locking clips, a light housing with three light bulb sockets and three halogen light bulbs.

To remove the light assemblies from 30- and 36-in models, and from the right side of the main oven and the left side of the companion oven on 48-in models, follow procedure A.

To remove the light assemblies from the left side of the main oven and the right side of the companion oven on 48-in. models, follow procedure B.

### Procedure A:

1. Remove the range from the installation. (See *Installation*.)
2. Remove the back panel. (See *Back Panel*.)
3. Remove the side access panel. (See *Side Access Panel*.)
4. Disconnect the oven light wire harness.

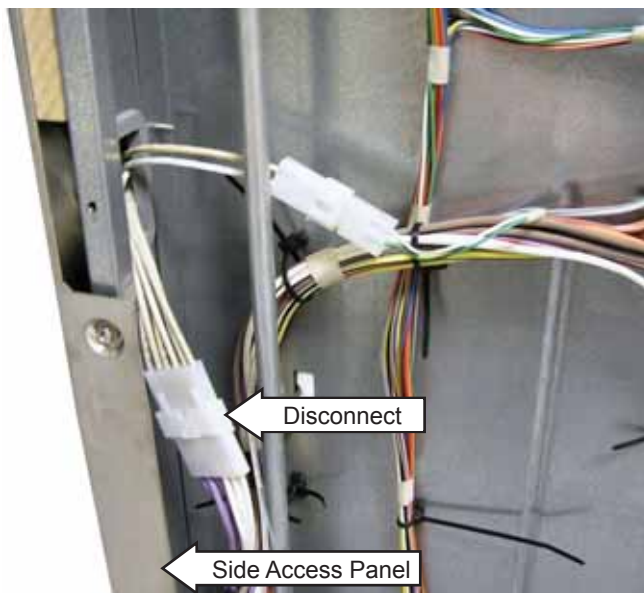

5. Remove the racks, rack support, and light cover. (See *Oven Light Bulbs*, this section.)
6. Remove the two 1/4-in. hex-head screws that attach the light housing to the oven liner.
7. Using a small flat blade screwdriver, pry out the 4 tabs that lock the housing to the oven liner.

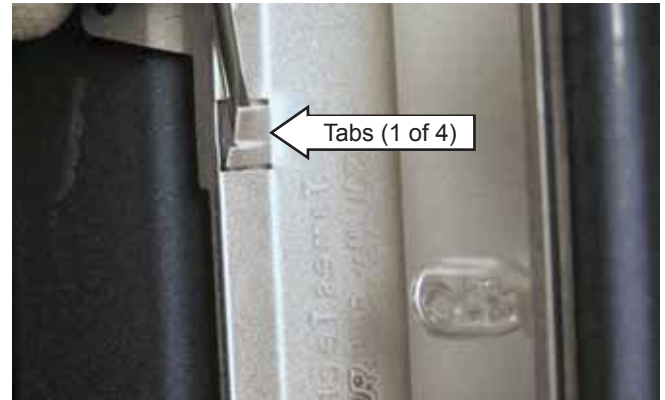

8. Separate the light housing from the oven liner.

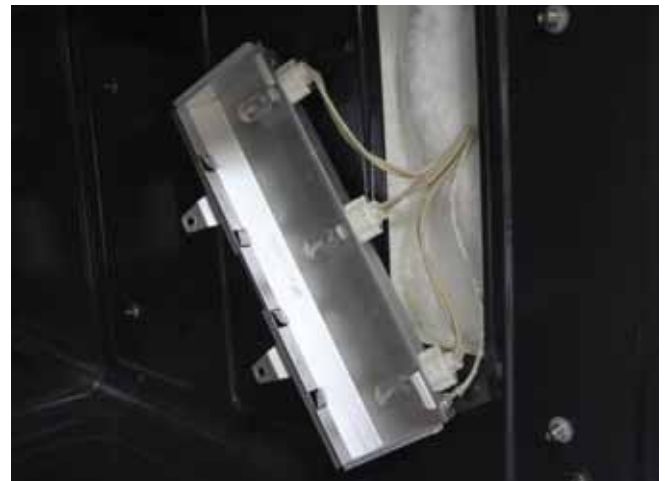

9. Carefully pull the oven light housing from the oven liner while guiding the wire harness through the wiring entry hole.



**Note:** Upon reassembly, ensure displaced insulation is returned to its original position.

(Continued next page)

### Procedure B:

1. Remove the racks, rack support, and light cover. (See **Oven Light Bulbs**, this section.)
2. Remove the two 1/4-in. hex-head screws that attach the light housing to the oven liner.
3. Using a small flat blade screwdriver, pry out the 4 tabs that lock the housing to the oven liner.
4. Separate the light housing from the oven liner.
5. Carefully pull the oven light housing from the oven liner while guiding the wire harness through the opening.
6. Disconnect the oven light wire harness.

**Note:** Upon reassembly, ensure displaced insulation is returned to its original position.

### Oven Light Bulbs

**Caution:** Before replacing a bulb, disconnect electrical power to the oven at the main fuse or circuit breaker panel.

Each oven is equipped with halogen light columns located on the side walls of the oven. The lights come on when the door is opened or when the oven is in a cooking cycle.

Each light assembly consists of a removable light cover with two locking clips and a light compartment with three halogen bulbs.

Be sure to let the light cover and bulb cool completely. For your safety, do not touch a hot bulb with bare hands or a damp cloth.

#### To remove oven light bulb:

1. Remove the racks from the oven. (See **Oven Racks**.)
2. Using a 7/16-in. nutdriver, remove the four nuts holding the rack supports to the oven wall.

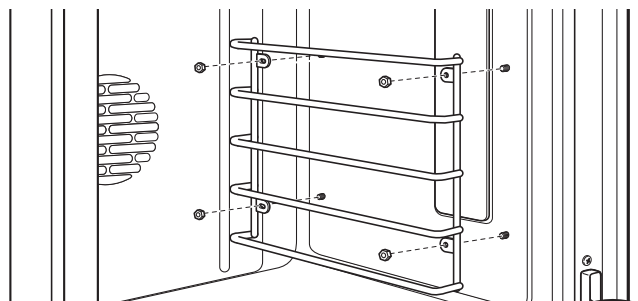

3. Remove the glass light cover by pulling its back edge out and rolling it toward you. Do not remove any screws.

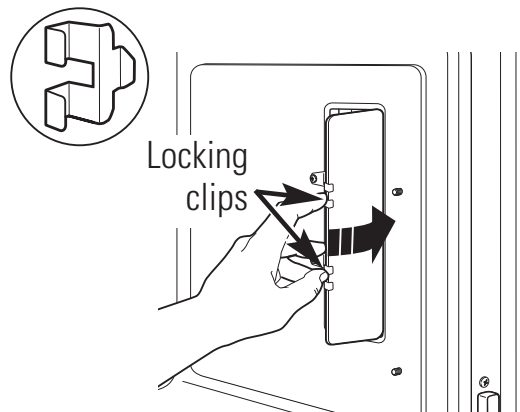

**Note:** If the locking clips fell from the glass lens cover, hold them on the cover, in the correct position, while replacing the cover on the light compartment.

4. Using gloves or a dry cloth, remove the burned-out light bulb by pulling it straight out.

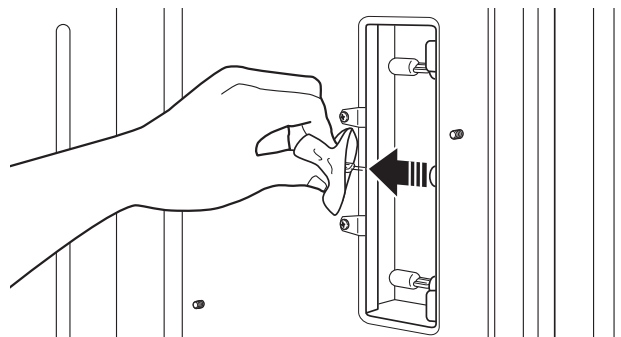

#### To replace:

Use a new 120-volt Halogen bulb, with G8 pins, not to exceed 25 watts.

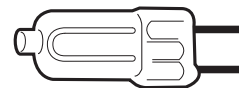

Replacement bulbs may be purchased by calling 800.626.2002. Order Part Number WB25T10064.

**Note:** The light cover must be in place when using the oven.

# Electronic Oven Control

## Overview

The Electronic Oven Control system consists of the logic board, power supply board, relay board, oven controls, oven sensor, and door lock assembly.

**Caution:** Certain components are electrically HOT when voltage is connected to range.

- Bake, broil, and convection units can be on at the same time.
- Bake, broil, and convection units can operate independently or simultaneously during preheat. There are five elements in each oven that can operate in any combination. There can be several minutes of off time between bake and broil unit operation after preheat.

COMPONENT OPERATION DURING GIVEN MODE														
	ELEMENTS						FANS							
Mode	Bake 1	Bake 2	Broil 1	Broil 2	Conv 1	Conv 2	Conv CW	Conv CCW	Cooling Lo	Cooling Hi	Oven Lamp	Latch Motor		
Preheat (Bake, Conv. Bake, Conv. Roast)	Cycling	Cycling	Cycling	Cycling	Off	Cycling	Off	On	On (above 200°F)	Off	On	Off		
Bake													Off	Off
Conv. Bake	Off	Off	Off	Off	Cycling	Cycling	Cycling	Cycling	Off	Off	On	Off		
Broil Hi			Cycling	Cycling	Off	Off	Off	Off						
Broil Lo							Cycling	Cycling					Cycling	Cycling
Conv. Broil							Off	Off					Off	Off
Proof			Off	Off	Off	Off	Off	Off					Off	Cycling
Clean	Cycling	Cycling	Cycling	Cycling	Off	Off	Off	Off	On	Off	On			

# Control Board Connector Locator

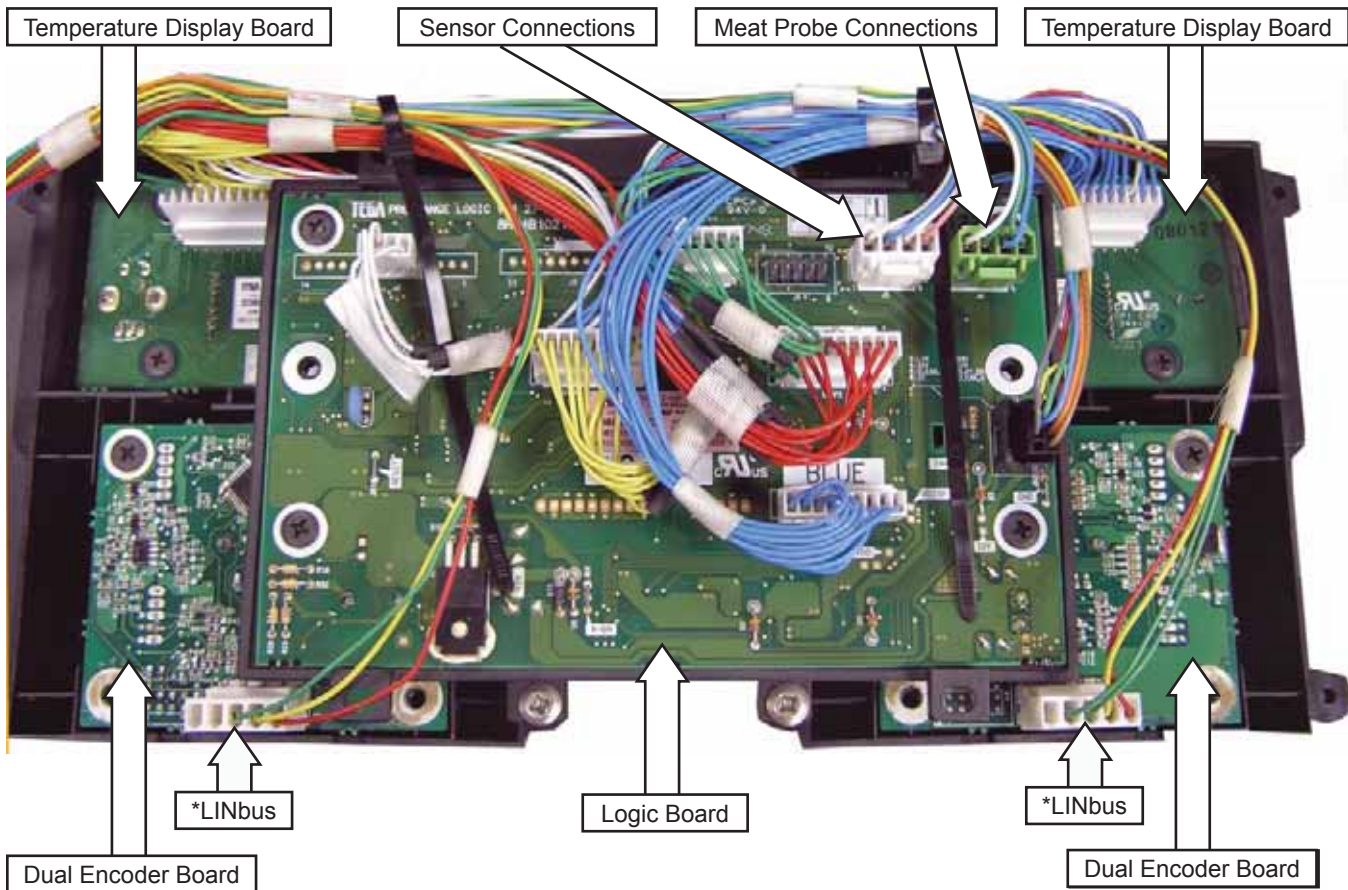

\*LINbus: (Local Interconnect Network) : A communication network comprised of a LIN master and one or more LIN slaves. In this double oven range, the logic board acts as the LIN master while the dual encoder boards, (temperature encoders), and relay boards are the LIN slaves. The logic board sends messages to the other components based on a predefined list of commands.

All the components receive a signal to perform a specific task, but only the appropriate component will act on the message and respond accordingly. The component which acts on the specific task is based on programming in the control. Since the LINbus signal is a digital control signal, special equipment, such as an oscilloscope, is required to measure it.

## Oven Relay Board

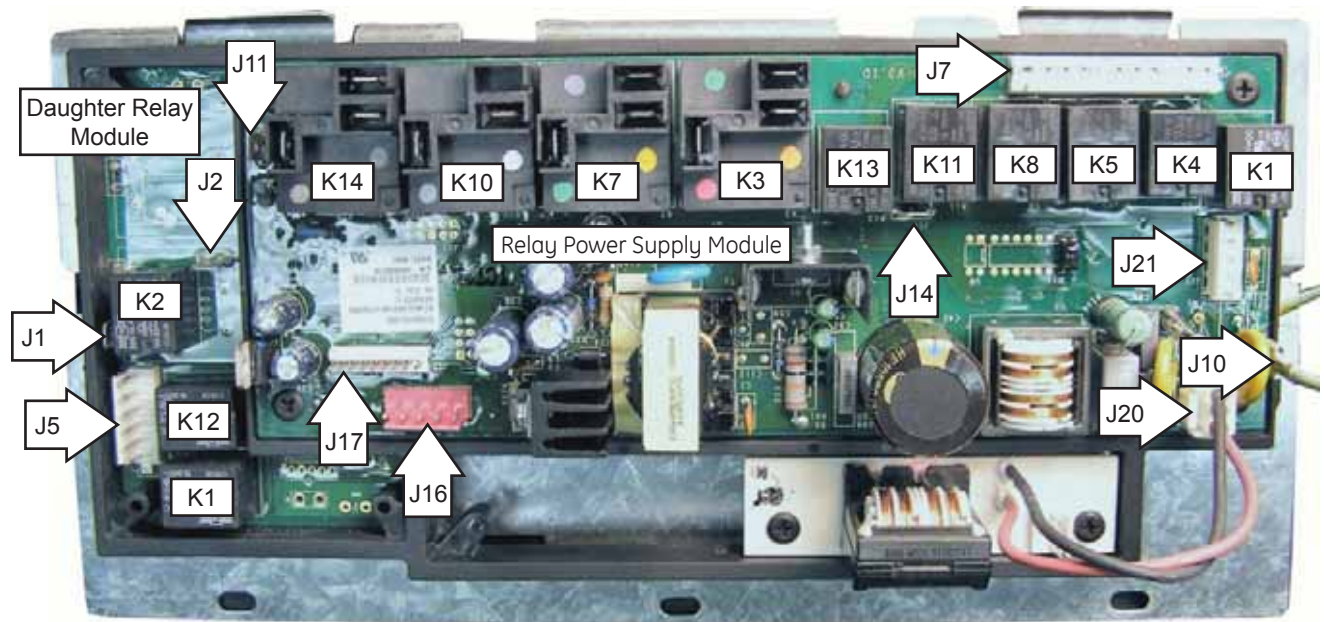

**Note:** The main oven relay board consists of a relay power supply module and a daughter relay module, available only as an assembly. Companion oven relay boards are similar, but will not have a power supply.

Relay Power Supply Module	J7	Door Lock,, Broil Element 2, Bake Element 2, Convection Element 2, L1, Convection Motor CW, Convection Motor CCW
	J10	Ground
	J11	Neutral
	J14	L1
	J16	Sail Switch, Door Unlock Switch, Door Lock Switch, Door Status Switch
	J17	LIN Connector
	J20	L1 and L2
	J21	Neutral
	K1	Convection Fan Direction
	K3	Broil Element 1
	K4	Convection Fan On/Off
	K5	Convection Element 2
	K7	Bake Element 1
	K8	Bake Element 2
	K10	Convection Element 1
K11	Broil Element 2	
K13	Door Lock	
K14	DLB (Double Line Break)	
Daughter Relay Module	J1	L1
	J2	Oven Lights
	J5	Cooling Fan Hi Speed, L1, Cooling Fan Low Speed
	K1	Cooling Fan Low Speed
	K2	Oven Light
K12	Cooling Fan High Speed	

# Oven Relay Board Wiring Diagrams

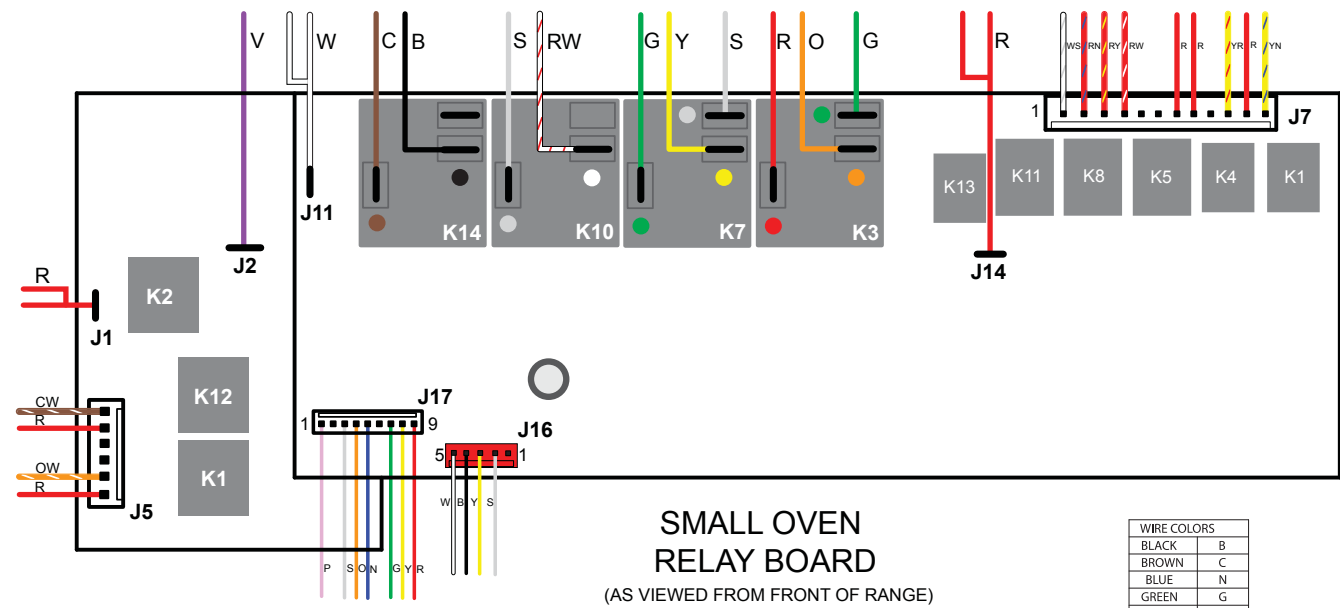
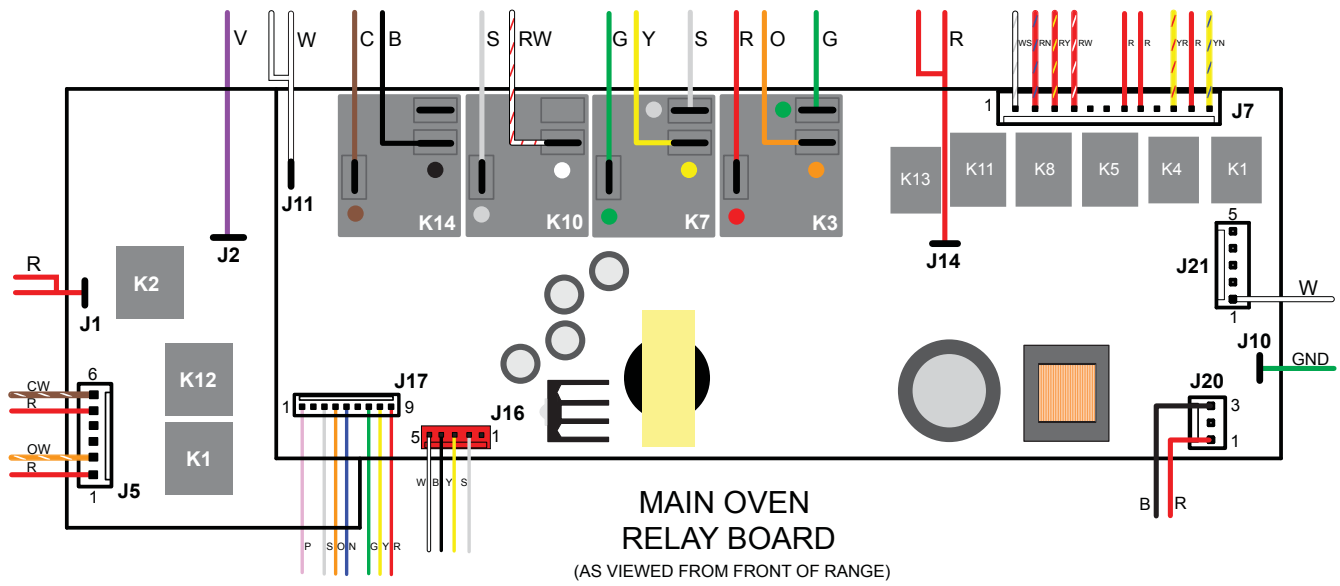

# Diagnostics and Service Information

## Factory Test Mode

The Factory Test mode can be accessed within the first 2 minutes of power up, before any other selections are made. Press and hold the **PUSH TO SELECT** knob for approximately 3 seconds within the first 2 minutes. The display will show "Prod". The options for Factory Test are cycled through by pressing the **TIMER** button. (See table next page.)



**Note:** To exit the Factory Test mode, hold the **PUSH TO SELECT** knob for 3 seconds.

**Note:** The table below shows the component sequence when Factory Test mode starts. This is a End-of-Line test and cannot be paused to test components.

Step	Sequence	Action
0	0.0 seconds	Wait
1	2.0 seconds	Turn on Bake 1 Element
2	4.0 seconds	Turn off Bake 1 Element and wait
3	5 seconds	Turn on Bake 2 Element
4	7 seconds	Turn off Bake 2 Element and wait
5	8 seconds	Turn on Broil 1 Element
6	10 seconds	Turn off Broil 1 Element and wait
7	11seconds	Turn on Broil 2 Element
8	13 seconds	Turn off Broil 2 Element and wait
9	14 seconds	Turn on Convection 1 Element
10	16 seconds	Turn off Convection 1 Element and wait
11	17 seconds	Turn on Convection 2 Element
12	19 seconds	Turn off Convection 2 Element and wait
13	20 seconds	Turn on Cooling Fan High
14	22 seconds	Turn off Cooling Fan High and wait
15	23 seconds	Turn on Cooling Fan Low
16	25 seconds	Turn off Cooling Fan Low and wait
17	26 seconds	Turn on Convection Fan CCW
18	28 seconds	Turn off Convection Fan CCW and wait
19	29 seconds	Turn on Convection Fan CW
20	31 seconds	Turn off Convection Fan CW and wait
21	32 seconds	Turn on Oven light
22	34 seconds	Turn off Oven Light
<b>If Single Oven</b>		
23a	35 seconds	Sound System Beep
<b>If Double Oven</b>		
23b	35 seconds	Turn on Bake Element 1
24	37 seconds	Turn off Bake Element 1 and wait
25	38 seconds	Turn on Bake Element 2
26	40 seconds	Turn off Bake Element 2 and wait
27	41 seconds	Turn on Broil Element 1
28	43 seconds	Turn off Broil Element 1 and wait
29	44 seconds	Turn on Broil Element 2
30	46 seconds	Turn off Broil Element 2 and wait
31	47 seconds	Turn on Convection Element 1
32	49 seconds	Turn off Convection Element 1 and wait
33	50 seconds	Turn on Convection Element 2
34	52 seconds	Turn off Convection Element 2 and wait
35	53 seconds	Turn on Cooling Fan High
36	55 seconds	Turn off Cooling Fan High and wait
37	56 seconds	Turn on Cooling Fan Low
38	58 seconds	Turn off Cooling Fan Low and wait
39	59 seconds	Turn on Convection Fan CCW
40	61 seconds	Turn off Convection Fan CCW and wait
41	62 seconds	Turn on Convection Fan CW
42	64 seconds	Turn off Convection Fan CW and wait
43	65 seconds	Turn on Oven Light 2
44	67 seconds	Turn off Oven Light 2
45	68 seconds	Sound System Beep

(Continued Next Page)

After completing the component sequence, pressing the **Timer** button scrolls through these available displays.

1st press displays ROM revision



2nd press displays EEPROM checksum



3rd press displays Probe temperature



4th press displays oven temperature



5th press displays all red LED segments



6th press displays all green LED segments



7th press displays EEPROM programming



8th press displays F-Codes



**Note:** 7 fault codes are stored in memory



**Note:** 6 communication faults are stored



## Failure Codes

The last 7 Failure (F) codes are stored in the nonvolatile memory, accessed through the factory test mode. All Failure (F) codes are suppressed from the display, except F2 and F9.

To access the last 7 F-codes, follow these steps:

1. Enter the factory test mode. (See **Factory Test Mode**.)
2. Press the **Timer** button to cycle through the factory test mode options.
3. Find the F-code menu. The display will show "F-co".
4. Press the **Mini-Knob** button to enter this menu.
5. Press the **Mini-Knob** button to cycle through F-codes. Press the **Timer** button to return to the factory test mode main menu.

FAILURE CODE	MEANING	CORRECTION
-F2-	Oven temperature Inside oven cavity as measured by sensor over 650°F unlatched or 915°F latched	<ul style="list-style-type: none"> <li>• Welded relay contacts</li> <li>• Airflow to rear of unit</li> <li>• High resistance in oven sensor leads/connectors (especially at sensor in rear)</li> </ul>
-F3-	Open oven sensor (over 2900 ohms)	<ul style="list-style-type: none"> <li>• Disconnect power. Disconnect sensor harness from control. Measure sensor resistance (white leads) to be 1080 ohms at room temperature with 2 ohms per degree change.</li> <li>• Look for damaged harness terminals if not a bad sensor.</li> </ul>
-F4-	Shorted oven sensor (under 950 ohms)	<ul style="list-style-type: none"> <li>• Disconnect power. Disconnect sensor harness from control. Measure sensor resistance (white leads) to be 1080 ohms at room temperature with 2 ohms per degree change.</li> <li>• Separate sensor from harness to determine fault.</li> </ul>
-F7-	Shorted key	Check logic display assembly. If rubber button pad is misaligned, correct; otherwise, replace control.
-F8-	EEPROM data shift failure	If repeated, replace.
-F9-	Cooling fan stalls or other cause of open sail switch	Suspect stalled cooling fan or airflow to control area.
-CX- -C1- -C4-	Communication Error	Check harness first and then replace component indicated by Cx Error Code.
-FC-	Door Latch Error	Inspect door latch and circuitry. Replace if switches are defective.

Communication errors stored:

- |   |   |
|---|---|
| C1 – Communication Fail with Main Relay Board   | C4 – Communication Fail with Aux. Relay Board   |
| C2 – Communication Fail with Upper Temp Encoder | C5 – Communication Fail with Lower Temp Encoder |
| C3 – Communication Fail with Upper Mode Encoder | C6 – Communication Fail with Lower Mode Encoder |

(Continued Next Page)

## Miswire Detection

A miswire error is detected if any of the power supply lines (L1, L2 or N) are wired incorrectly or not present. If detected, the control will beep continuously and scroll "Bad LinE" across available displays (main and companion oven, if applicable).

<b>L1-L2</b>	<b>L1-N</b>	<b>Status</b>
240VAC	Voltage present	Normal 240 VAC operation
240VAC	No voltage	Miswire error
208VAC	Voltage present	Normal 208 VAC operation
208VAC	No voltage	Miswire error
<150VAC	No voltage	Miswire error
<150VAC	Voltage present	Demo mode

## Oven Sensor, Sail, and Door Switch Test

**Note:** See *Lock Assembly* for door switch function explanation.

1. Remove power from oven.
2. The resistance measurements are made on the main logic board at connector J5 and J6, and the oven relay board at connectors J16 and J17.
3. If abnormal reading is observed, wiggle leads at disconnect block. If any variation, replace.

MAIN AND COMPANION OVENS		
Circuit	Terminals	Ohms
Oven Sensor A	Main Logic Board J5, pin 1 to pin 2	1091 $\Omega$ @ Rm. Temp. 1654 $\Omega$ @ 350°F
Oven Sensor B	Main Logic Board J5, pin 3 to pin 4	2634 $\Omega$ @ 865°F
Door Latched	Relay board J17 pin 1 to J16 pin 3 Relay board J17 pin 1 to J16 pin 4	0 $\Omega$ Open
Door Unlatched	Relay board J17 pin 1 to J16 pin 4 Relay board J17 pin 1 to J16 pin 3	0 $\Omega$ Open
Sail Switch Cooling Fan On	Relay board J17 pin 1 to J16 pin 5	0 $\Omega$
Sail Switch Cooling Fan Off	Relay board J17 pin 1 to J16 pin 5	Open
Meat Probe A	Main Logic Board J6, pin 1 to pin 2	30-50K $\Omega$ @ Rm. Temp.
Meat Probe B	Main Logic Board J6, pin 3 to pin 4	30-50K $\Omega$ @ Rm. Temp.
Door Status Door Open	Relay Board J17 pin 1 to J16 pin 2	0 $\Omega$
Door Status Door Closed	Relay Board J17 pin 1 to J16 pin 2	Open

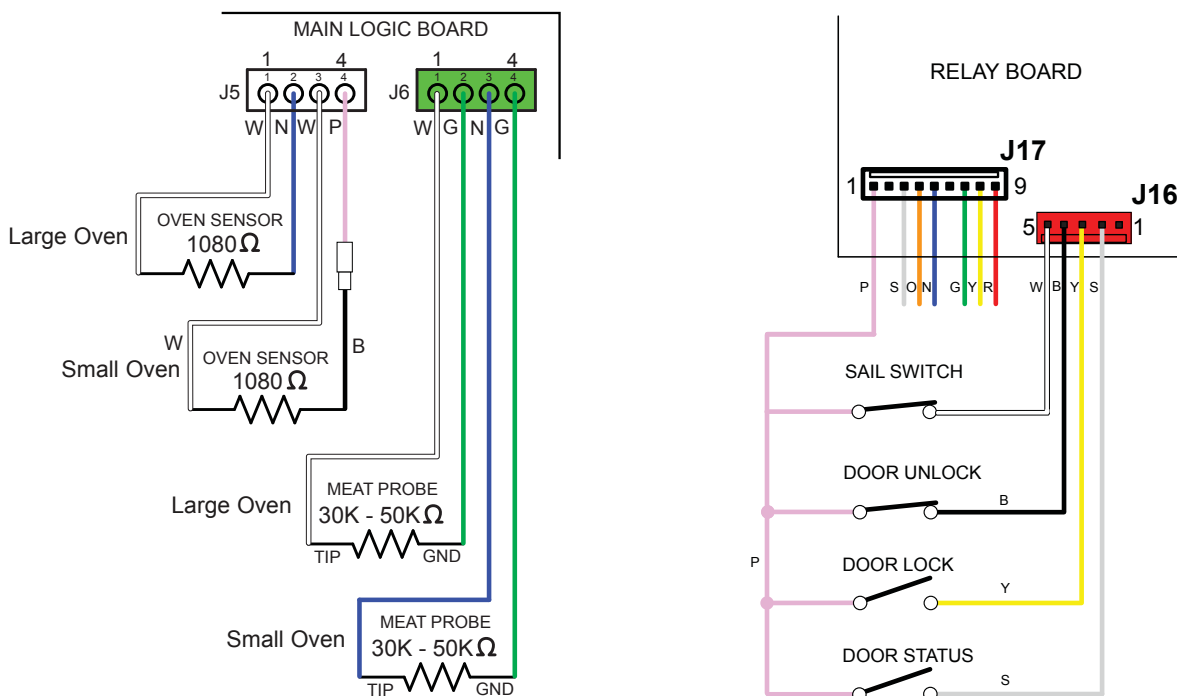



# Rangetop Wiring Diagram

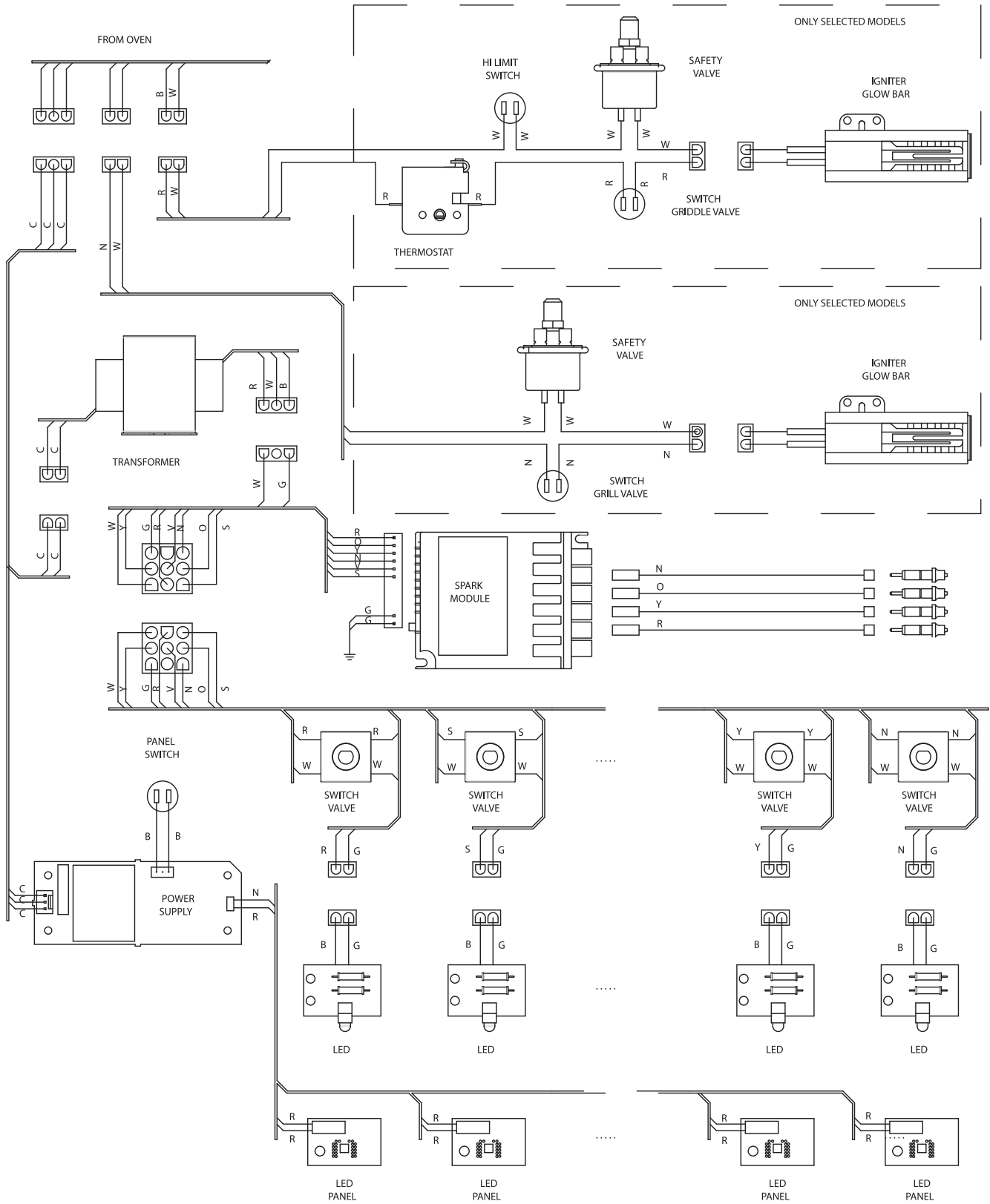

## Surface Component Circuits

### Surface Burner (4 burner model shown)

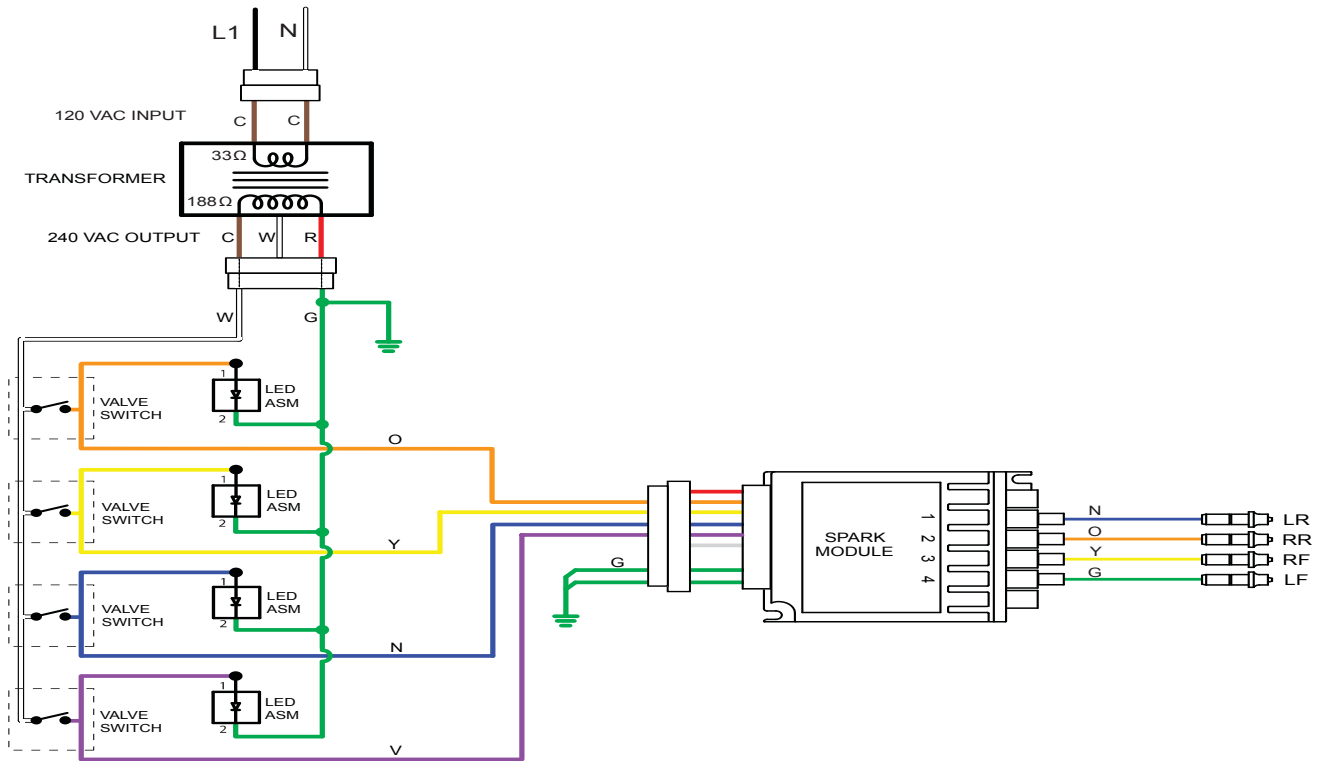

### LED Board

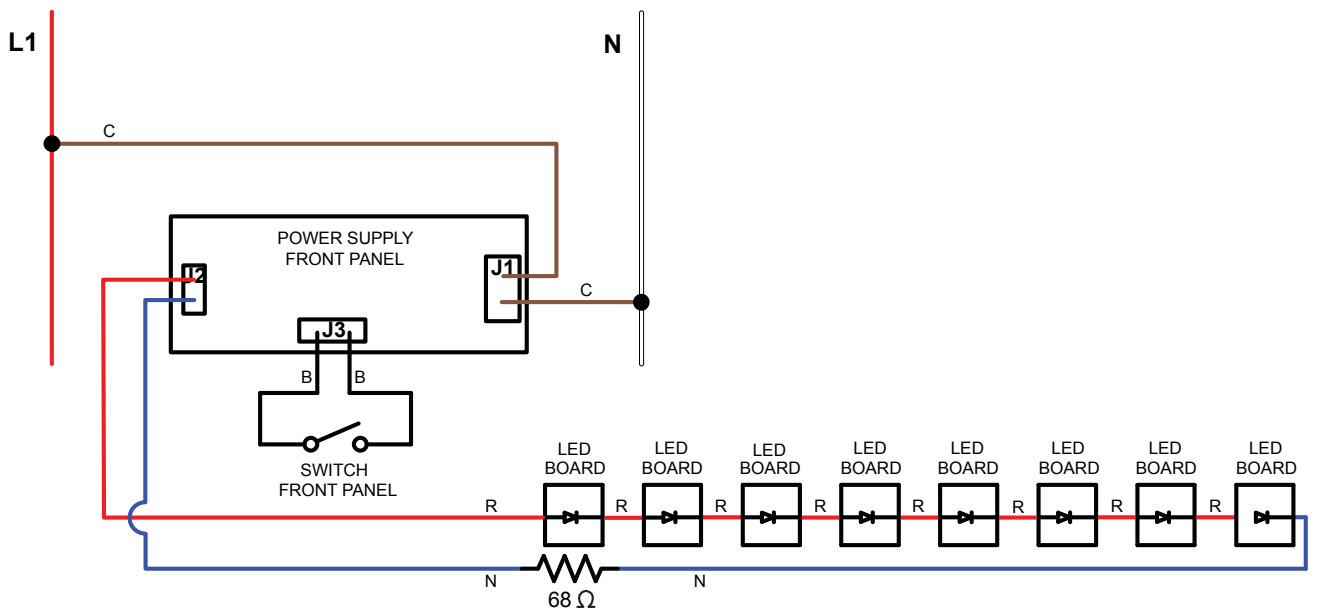

The resistor is a part of the LED harness.

The resistors have different values to accommodate the different number of LEDs on each model (same power supply)

9 bulbs (ZDP486) - no resistor

8 bulbs (ZDP484) - 68 ohm resistor

7 bulbs (ZDP366, ZGU486) - 68 ohm resistor

6 bulbs (ZDP364, ZGU484, ZGU366) - 150 ohm resistor

5 bulbs (ZDP304, ZGU364) - 150 ohm resistor

(Continued next page)



# Oven Component Circuits

## Preheat Circuit

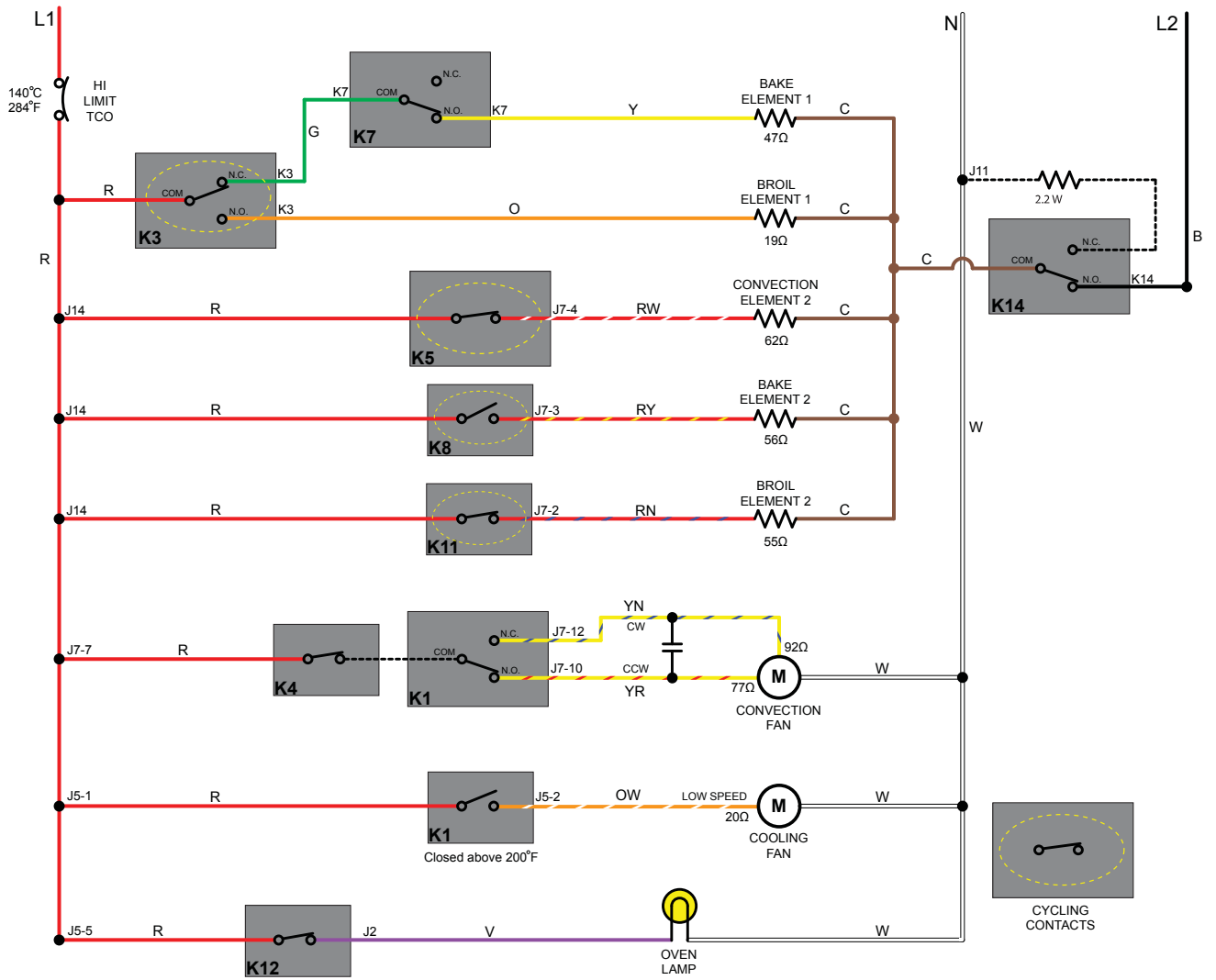

## Bake Circuit

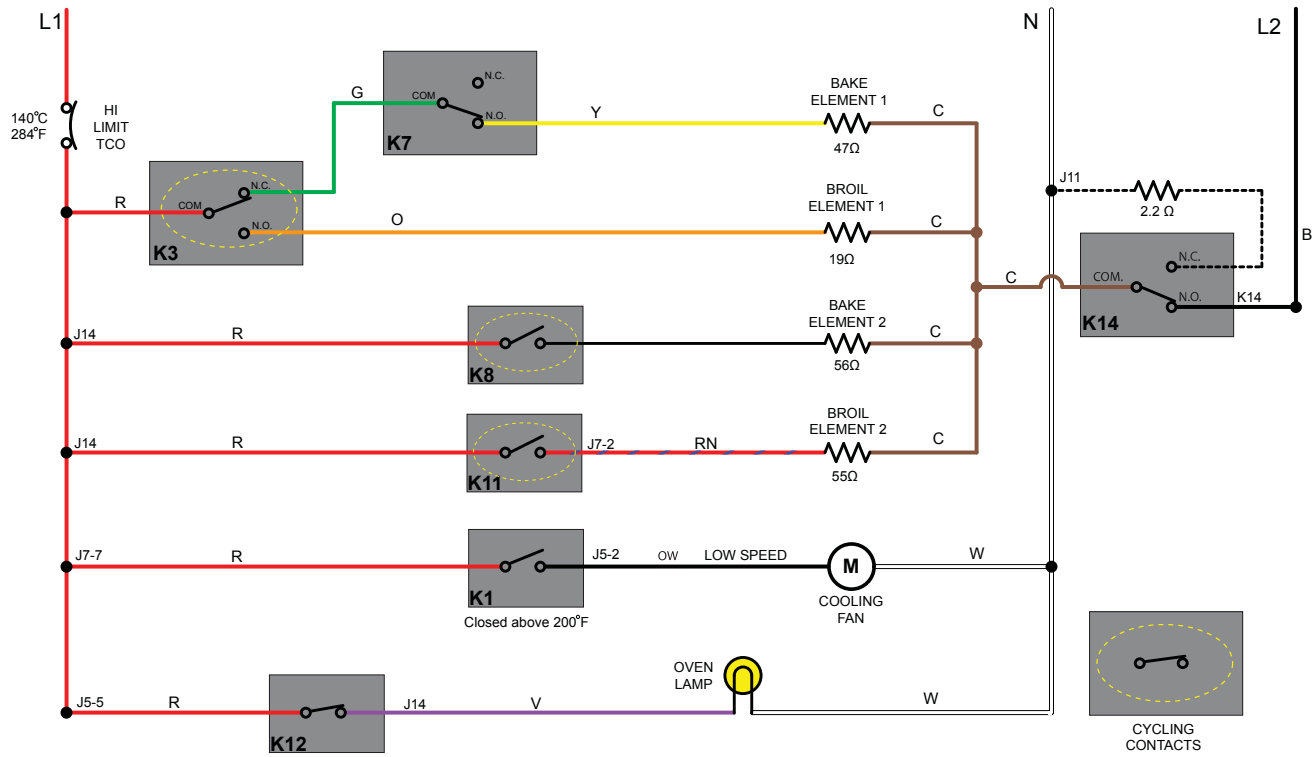

## Broil Circuit

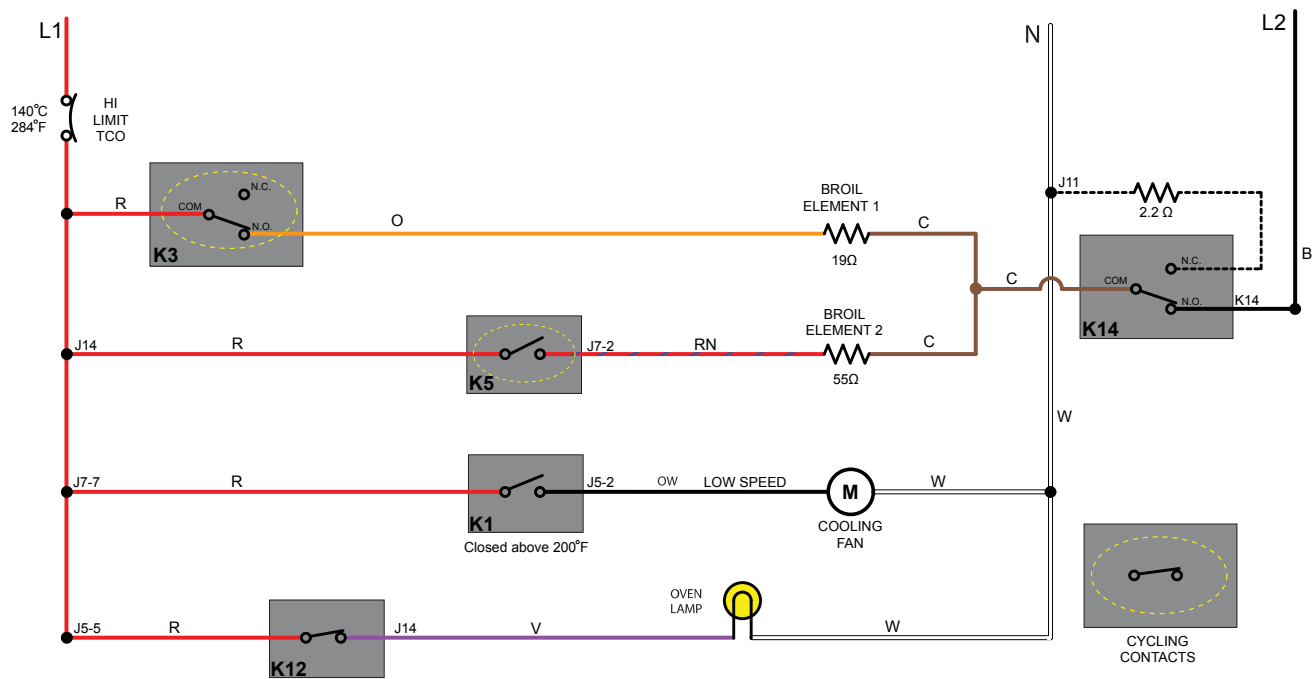

## Convection Circuit

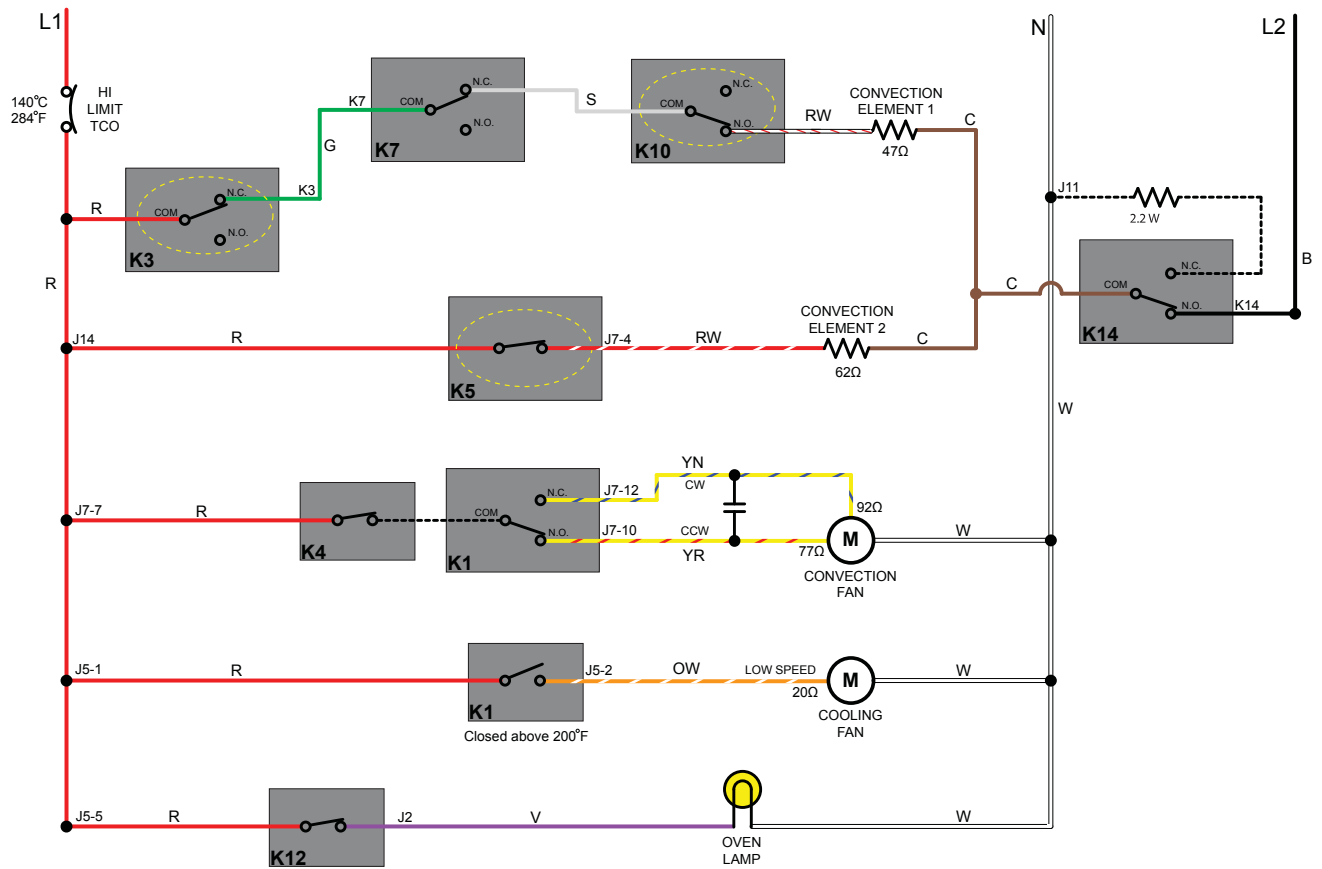

## Clean Circuit

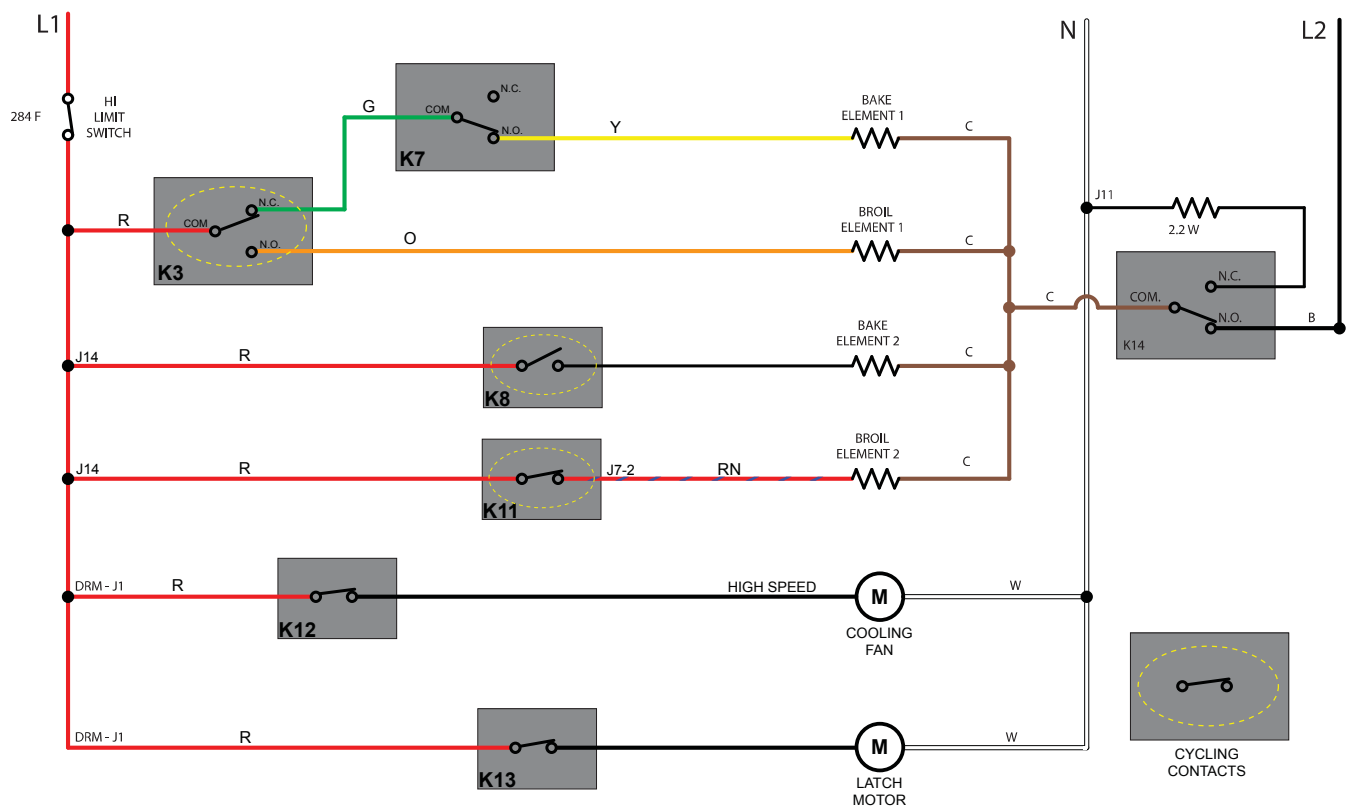

# Optional Accessories

## Optional Backsplash Kits

Two optional backsplash kits are available for ranges and rangetops:

- 12-inch tall stainless steel backsplash
- 36-inch tall backsplash equipped with a shelf that can adjust from 30" to 36" height.

**Note:** All backsplashes attach to the back wall and not the range or rangetop itself.

12-inch high backsplash available:

- ZX12B48PSS, for 48 in. wide units
- ZX12B36PSS, for 36 in. wide units
- ZX12B30PSS, for 30 in. wide units



30-to 36 inch adjustable height backsplash with shelf available:

- ZXADJB48PSS, for 48 in. wide units
- ZXADJB36PSS, for 36 in. wide units
- ZXADJB30PSS, for 30 in. wide units



## Optional Black Knob Kits

Optional black knob kits are available for ranges and rangetops.

Range Models	Part Number
ZDP304N/LPSS	WB03K10268
ZDP366N/LPSS	WB03K10269
ZDP364N/LRPSS	WB03K10270
ZDP364N/LDPSS	WB03K10271
ZDP484N/LGPSS	WB03K10272
ZDP486N/LRPSS	WB03K10273
ZDP486N/LDPSS	WB03K10274

Rangetop Models	Part Number
ZGU366N/LPSS	WB03K10275
ZGU364N/LRPSS	WB03K10276
ZGU364N/LDPSS	WB03K10277
ZGU484N/LGPSS	WB03K10278
ZGU486N/LRPSS	WB03K10279
ZGU486N/LDPSS	WB03K10280



Black Oven Knob Shown

## Prorange Sales Demo Kit

A sales demo kit is available that activates all lights and control displays. (Pub Number 24-M488.)

Kit Wiring Diagram

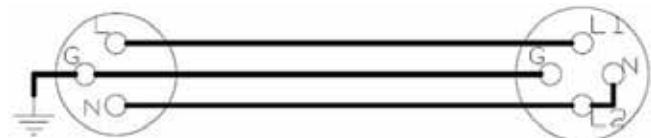

**Note:** 120 VAC applied to L1 and L2 (note jumper between L2-N)

# Warranty-Rangetop

## **YOUR MONOGRAM RANGETOP WARRANTY**

***Staple sales slip or cancelled check here. Proof of original purchase date is needed to obtain service under warranty. Please have serial number and model number available when calling for service.***

### **WHAT IS COVERED**

#### **LIMITED TWO-YEAR WARRANTY**

For two years from date of original purchase, we will provide, free of charge, parts and service labor in your home to repair or replace **any part of the rangetop** that fails because of a manufacturing defect.

#### **LIMITED FIVE-YEAR WARRANTY**

For five years from the date of original purchase, we will provide, free of charge, replacement **gas surface burners** if they fail in normal household use. (The grill and griddle are not included.) You pay for the service trip to your home and all service labor charges.

This warranty is extended to the original purchaser and any succeeding owner for products purchased for ordinary home use in the 48 mainland states, Hawaii and Washington, D.C. In Alaska the warranty is the same except that it is LIMITED because you must pay to ship the product to the service shop or for the service technician's travel costs to your home.

All warranty service will be provided by our Factory Service Centers or by our authorized Customer Care® servicers during normal working hours.

Should your appliance need service, during warranty period or beyond, in the U.S.A. call 800.444.1845. In Canada: 800.561.3344

### **WHAT IS NOT COVERED**

- Service trips to your home to teach you how to use the product.
  - Discoloration of the griddle plate.
  - Replacement of house fuses or resetting of circuit breakers.
  - Incidental or consequential damage caused by possible defects with this appliance.
  - Damage after delivery.
  - Damage to the product caused by accident, fire, floods or acts of God.
  - Failure of the product if it is used for other than its intended purpose or used commercially.
  - Improper installation, delivery or maintenance.
- If you have an installation problem, contact your dealer or installer. You are responsible for providing adequate electrical, gas, exhausting and other connecting facilities as described in the Installation Instructions provided with the product.
- Product not accessible to provide required service.

***EXCLUSION OF IMPLIED WARRANTIES—Your sole and exclusive remedy is product repair as provided in this Limited Warranty. Any implied warranties, including the implied warranties of merchantability or fitness for a particular purpose, are limited to one year or the shortest period allowed by law.***

Some states do not allow the exclusion or limitation of incidental or consequential damages, so the above limitation or exclusion may not apply to you. This warranty gives you specific legal rights, and you may also have other rights which vary from state to state.

To know what your legal rights are in your state, consult your local or state consumer affairs office or your state's Attorney General.

**Warrantor: General Electric Company, Louisville, KY 40225**

# Warranty-Range

## YOUR MONOGRAM RANGE WARRANTY

***Staple sales slip or cancelled check here. Proof of original purchase date is needed to obtain service under warranty. Please have serial number and model number available when calling for service.***

### WHAT IS COVERED

#### LIMITED TWO-YEAR WARRANTY

For two years from date of original purchase, we will provide, free of charge, parts and service labor in your home to repair or replace **any part of the range** that fails because of a manufacturing defect.

#### LIMITED FIVE-YEAR WARRANTY

For five years from the date of original purchase, we will provide, free of charge, replacement **gas surface burners** if they fail in normal household use. (The grill, griddle and oven burners are not included.) You pay for the service trip to your home and all service labor charges.

#### LIMITED LIFETIME WARRANTY

For the lifetime of the gray porcelain enamel oven racks, we will provide, free of charge, replacement **racks** if they fail in normal household use. You pay for the service trip to your home and all service labor charges.

This warranty is extended to the original purchaser and any succeeding owner for products purchased for ordinary home use in the 48 mainland states, Hawaii and Washington, D.C. In Alaska the warranty is the same except that it is LIMITED because you must pay to ship the product to the service shop or for the service technician's travel costs to your home.

All warranty service will be provided by our Factory Service Centers or by our authorized Customer Care® servicers during normal working hours.

Should your appliance need service, during warranty period or beyond, in the U.S.A. call 800.444.1845. In Canada: 800.561.3344

### WHAT IS NOT COVERED

- Service trips to your home to teach you how to use the product.
- Discoloration of the griddle plate or oven racks.
- Chipping of porcelain enamel grates or oven racks.
- Replacement of house fuses or resetting of circuit breakers.
- Incidental or consequential damage caused by possible defects with this appliance.
- Damage after delivery.
- Damage to the product caused by accident, fire, floods or acts of God.
- Failure of the product if it is used for other than its intended purpose or used commercially.
- Improper installation, delivery or maintenance.  
If you have an installation problem, contact your dealer or installer. You are responsible for providing adequate electrical, gas, exhausting and other connecting facilities as described in the Installation Instructions provided with the product.
- Product not accessible to provide required service.

**EXCLUSION OF IMPLIED WARRANTIES—Your sole and exclusive remedy is product repair as provided in this Limited Warranty. Any implied warranties, including the implied warranties of merchantability or fitness for a particular purpose, are limited to one year or the shortest period allowed by law.**

Some states do not allow the exclusion or limitation of incidental or consequential damages, so the above limitation or exclusion may not apply to you. This warranty gives you specific legal rights, and you may also have other rights which vary from state to state.

To know what your legal rights are in your state, consult your local or state consumer affairs office or your state's Attorney General.

**Warrantor: General Electric Company, Louisville, KY 40225**